

ColdAIR

ADIABATIC EVAPORATIVE AIR COOLER

MODEL: FPA KITCHEN 5.0



Installation, Operation and Maintenance Instruction Manual





COLD AIR – FPA KITCHEN 5.0

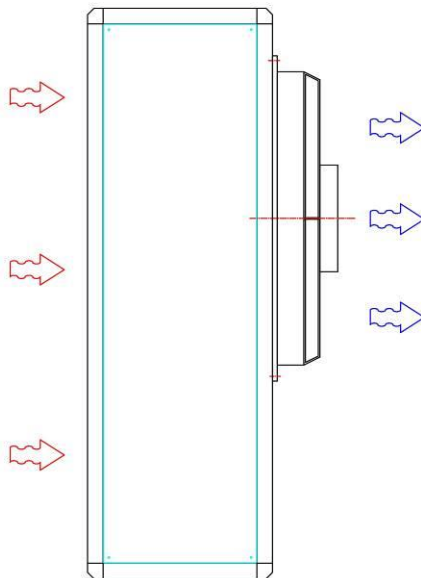
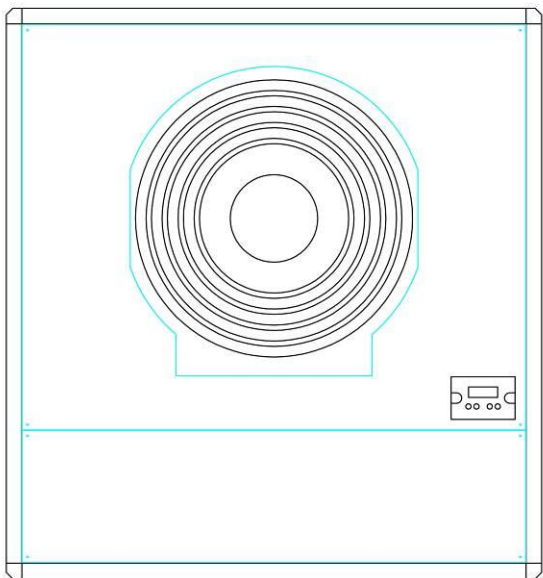



INDEX

MANUFACTURER.....	4
GENERAL INFORMATION.....	4
User information.....	5
SECTION 1 – TECHNICAL CHARACTERISTICS.....	6
1.1 Machine identification data	6
1.2 Presentation of <i>COLD AIR Evaporative Cooler Mod. "FPA Kitchen"</i>	6
1.3 Technical characteristics	6
1.4 Intended use	7
1.5 Electrical boards.....	8
1.6 Improper use.....	8
SECTION 2 – PACKAGING, HANDLING AND TRANSPORTATION.....	9
2.1 Receipt	9
2.2 Handling and transportation.....	9
2.3 Lifting	9
2.4 Unpacking	10
2.5 Storage.....	10
SECTION 3 – POSITIONING AND INSTALLATION	11
3.1 General warnings about installation	11
3.2 Positioning and installation of FPA-KITCHEN Air Cooler.....	11
3.3 Connection to power supply	13
3.4 Connection to the water supply	16
4.1 Protection devices.....	18
4.2 Work-clothing	18
4.3 Residual risks.....	18
4.4 Emergency situations	18
SECTION 5 – USE OF FPA-KITCHEN EVAPORATIVE COOLER	19
5.1 Control panel.....	19
5.2 – Description of controls and signals.....	20
5.2.1 Control panel description.....	20
5.2.2 Signals description.....	21
5.4 Operation	22
5.5 Change of the circulating water	22
5.6 Shut-down.....	22
5.6.1 Shutdown automatic washing cycle	23
Notes about the Machine operation	23
5.7 Air changes	23
5.8 Commissioning and first start-up	24
5.9 Seasonal stop	25
5.10 Operation anomalies.....	25
5.11 Safety signs onboard the Machine	26
SECTION 6 – MAINTENANCE	27
6.1 End-season maintenance	27
6.2 Pre-season maintenance.....	27
6.3 Maintenance safety norms	28
6.4 Replacement of the evaporative panels.....	30
6.5 Technical assistance request.....	31
SECTION 7 – DISASSEMBLY	32
7.1 Putting out-of-service.....	32
SECTION 8 – TECHNICAL DRAWINGS	33





MANUFACTURER

IMPRESIND SRL

Production site: Via Primo Maggio 24, 20064 Gorgonzola – Milan (ITALY)

 +39 02 95741932

 +39 02 95740637

 info@impresind.com

 www.impresind.com

GENERAL INFORMATION

PREAMBLE

Dear Customer,

We thank you for choosing an IMPRESIND product and we would like to inform you of the following:

- The content of this document is for information purpose only and it is subject to modifications without notice;
- This manual cannot be partially or fully reproduced, transmitted, copied or stored in an archive system in any mechanical, magnetic, optical, chemical or other form or means without written authorization by IMPRESIND SRL;
- This manual must be kept and conserved until the final dismantling of the machine; in case of transfer, it must be handed over to the new owner.
- If a fault occurs causing machine shutdown, IMPRESIND SRL is not liable in any way for any damage caused by the shutdown and in no way the warranty period is extended.



User information

This manual is an integral part of the machine itself; it must be kept and be readily available to the personnel in charge of use and maintenance of this machine.

Personnel in charge of operation and maintenance of the machine must be fully aware of its content before putting the machine into service.

In the event of loss or damage to this manual, request a copy immediately by contacting the Technical Assistance Service at IMPRESIND SRL, referring to the identification data of the machine, as shown on the machine identification plate and on the cover of the present manual.

The machine complies with the following European Community Directives:

- **2006/42/EEC** ⇒ Machinery Directive
- **2014/35/EEC** ⇒ Low Voltage Directive
- **2014/30/EEC** ⇒ Electromagnetic Compatibility Directive
- **2009/125/EEC** ⇒ Energy Related Products (ERP) Directive



IT IS ABSOLUTELY FORBIDDEN TO MAKE MODIFICATIONS TO THE MACHINE AND ITS DESTINATION OF USE.



IMPRESIND SRL declines all responsibility for any damages which may be, directly or indirectly, caused to exposed persons or property, due to improper use or use of the machine for different purposes other than the design purposes, incorrect installation, inappropriate power supply, different or changes to the installation environment from the one declared during order confirmation, grave deficiency of maintenance, unauthorized alterations and modifications, use of non-original spare parts, removal of the protection guards, inobservance of the instructions for use, negligence, etc.



COLD AIR – FPA KITCHEN 5.0 Section 1 – Technical Characteristics

SECTION 1 – TECHNICAL CHARACTERISTICS

1.1 Machine identification data

Machine identification data are shown on the machine identification plate, as well as on the warranty document supplied to the customer along with the related documentation.



In case of Technical Assistance request or spare parts, always quote the model and the machine serial number.

1.2 Presentation of **COLD AIR Evaporative Cooler Mod. "FPA Kitchen"**

To improve the summer microclimate inside a production facility, a commercial space or other indoor places, the environment must be ventilated with many new and filtered air-changes, possibly cooled. In case of large premises, for example industrial ones, an air conditioning system is often not advisable since, due to the large volume of air to be cooled and the thermal loads to be neutralized, the quantity of energy required is very high, and the cooling effect is reduced by the exhaust air extraction system and by the frequent opening of the doors for carrying out the activity.

An excellent solution is represented by the evaporative cooler system that cools the air with a natural principle: the air passes through special wet filters, gives way part of its heat during the process of evaporation of water and lowers its temperature. The absence of refrigeration equipment reduces energy consumption to a minimum and allows large volumes of air to be treated for the many air-changes needed.

1.3 Technical characteristics

	UoM	FPA KITCHEN 5.0
Air flow rate		
Max	m ³ /h	5000
Min		1000
Power supply Voltage	V	230V – 50Hz
Electric Current	A	3
Total Electric Power	kW	0.45
Water Consumption (Average)*	lt/h	13
Water Inlet Ø	inch	3/4
Water Outlet Ø	mm	22
Evaporative panel		
- Thickness	mm	100
- Surface area	m ²	0,7
- Average saturation Efficiency	%	88
Dimensions: L x P X H	mm	1005x347x1070
Weight (empty - full)	kg	55 - 75

* Test conditions: E. Temp.= 33°C – R. Hum. 60%



COLD AIR – FPA KITCHEN 5.0

Section 1 – Technical Characteristics

1.4 Intended use

The **ColdAir** Evaporative Cooler can be installed in any environment where it is necessary to improve the microclimate, where the environment must be ventilated with frequent changes of fresh, filtered and possibly cool air, such as:

- production facilities and units
- commercial premises and warehouses
- sport venues in general, such as gymnasiums;
- professional kitchens



The machine must NOT be used for a different use than its designed use for any reason whatsoever or used in a different way than stated in this manual. DO NOT install the machine in external areas; the machine must be installed inside the area to be treated, except by specific approval of the manufacturer.



DO NOT start-up the machine if the evaporative panels are not installed.



When the machine is running, do not touch the fan. Mechanical danger - It is forbidden to work on moving parts.



COLD AIR – FPA KITCHEN 5.0

Section 1 – Technical Characteristics

1.5 Electrical boards

The control panel and the power panel are incorporated inside the Machine and are manufactured according to EN 60204/1 regulations.



IT IS ABSOLUTELY FORBIDDEN TO MAKE MODIFICATIONS TO THE ELECTRICAL BOARD.



IT IS ABSOLUTELY FORBIDDEN TO USE WATER TO PUT OUT FIRES

1.6 Improper use

The machine cannot be used for other purposes than those stated at paragraph 1.4 of this instruction manual.

Any machine modification is forbidden and determines the loss of the product warranty. In case of product modification IMPRESIND SRL declines all responsibility for the product.



IT IS ABSOLUTELY FORBIDDEN TO INSTALL COLD AIR EVAPORATIVE COOLERS IN POTENTIALLY EXPLOSIVE ENVIRONMENTS.



COLD AIR – FPA KITCHEN 5.0
Section 2 – Packaging, Handling and Transportation

SECTION 2 – PACKAGING, HANDLING AND TRANSPORTATION

2.1 Receipt

When the Machine is delivered, the Customer **MUST** check its integrity and conditions.



***Check the packaging and its contents.
If damage due to transportation is detected,
make a reserve for the damage on the shipping
documents and get them signed by the shipping
agent; then send a copy by fax or email to
IMPRESIND SRL.***

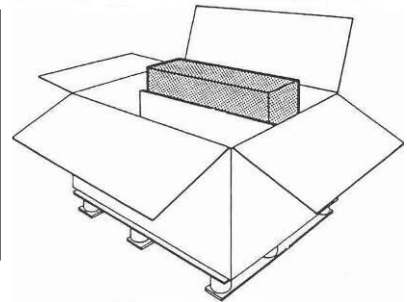

2.2 Handling and transportation



***In order to avoid any damage to the machine, pay great attention when
unloading from the transportation mean, handling and positioning.
Avoid contact with elements that may damage the machine.***



***IMPRESIND SRL declines any responsibility for damages caused during
transportation, loading and unloading of the machine.***

2.3 Lifting



***Make sure that the capacity of the lifting equipment is adequate for the weight
of the machine.
Lifting must be carried out by qualified personnel only.***



***IT IS ABSOLUTELY FORBIDDEN to remain under suspended loads and inside
the movement area of the lifting equipment.***



COLD AIR – FPA KITCHEN 5.0

Section 2 – Packaging, Handling and Transportation

2.4 Unpacking

Take the Machine to the place where it will be installed.

Free all wrapped or enclosed components from the packaging and collect them in order to prevent potential danger of fire and suffocation of people or animals.

Leave the Machine on its transportation-packaging base, with any protection guards mounted, so that the lower part is raised from the floor and is not damaged, until the machine is installed on the provided devices.



Disposal of packaging materials must be done in conformity to the regulations in force in the country of destination where the machine is installed.

2.5 Storage

During transportation and storage, make sure that the ambient temperature is between -10°C and +50°C.

If the machine has to be stored, make sure that the relative humidity in the warehouse is between 5% and 90%.



SECTION 3 – POSITIONING AND INSTALLATION

3.1 General warnings about installation

Before proceeding with the installation make sure that the machine has been unpacked and that its integrity has been checked.

Positioning and installation of the Machine must be carried out by qualified personnel and by observing the laws in force in the country of destination.

3.2 Positioning and installation of FPA-KITCHEN Air Cooler

COLD AIR Air Coolers Mod. FPA-KITCHEN are machineries designed for wall or window installation. These machines must be installed in the internal side of the premise. Thanks to their small size and relative low weight, they are easily handled and positioned with a simple lifting equipment.

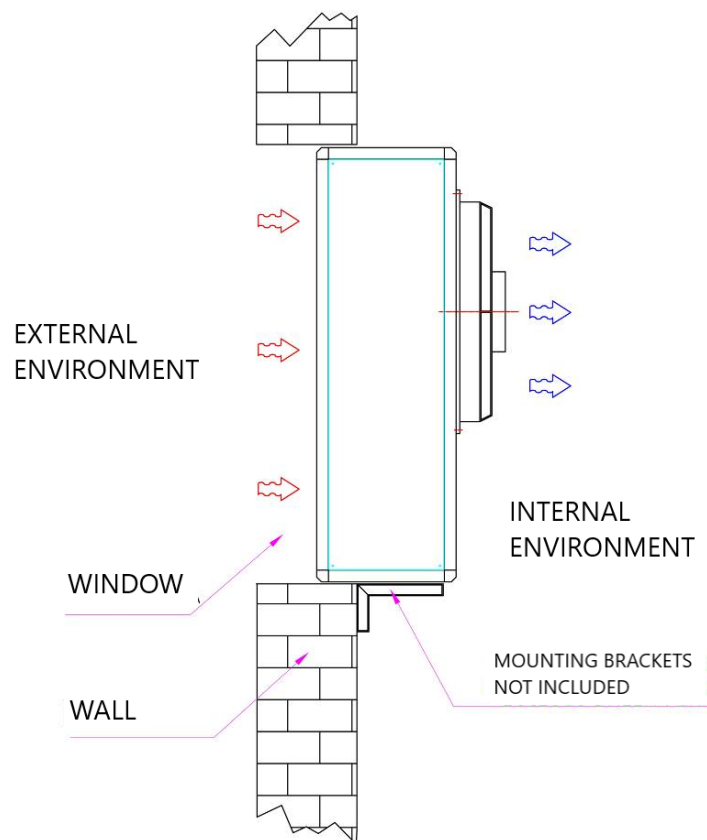



COLD AIR – FPA KITCHEN 5.0 Section 3 – Protection Devices

Please bear in mind that the support mounting brackets are not included (optional), anyhow the Machine is supplied with threaded inserts as parts of the machine frame to allow the fixing / anchoring of the Machine.

It is very important to leave the necessary free space around and below the Machine to allow an easy connection of various utilities (e.g. power supply, water supply and drainage).



It is strictly forbidden to put or hang weights on the Machine, and to use it as a support surface.

The following pictures shows some examples of possible installation.

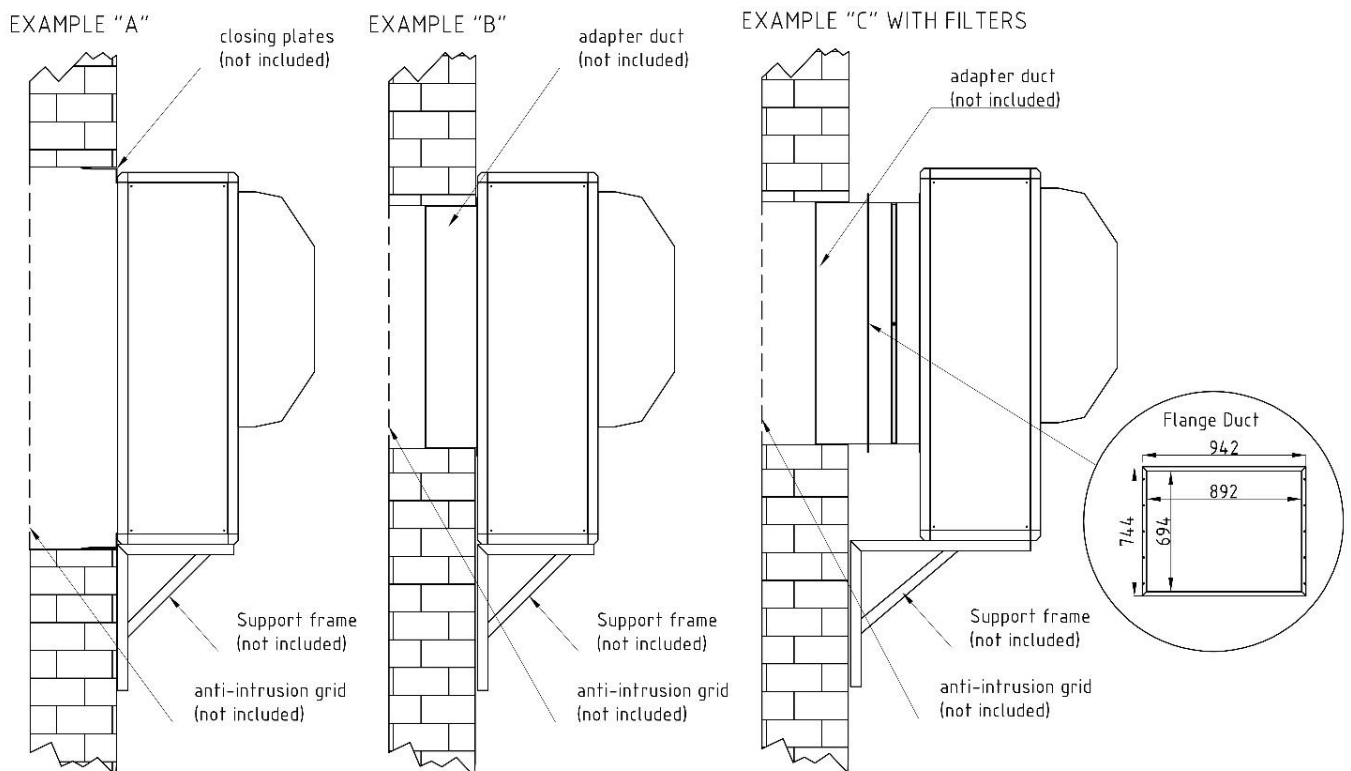



COLD AIR – FPA KITCHEN 5.0 Section 3 – Protection Devices

3.3 Connection to power supply



**Connection to the power supply must be carried out by qualified personnel.
All components used to connect the power supply must be certified.
Before working on the power supply cables, make sure that power is cut-off.**



Provide an efficient grounding connection

The power supply foreseen is: **230 V ~ 50 Hz**

Each Machine must be connected to the power supply **using an omnipolar circuit-breaker**. The isolator must have a distance between its contacts of at least 3 mm for each pole, and it must be placed in a position that can be easily reached by the user.

The electrical system must be designed and built according to the regulations in force in the country where the Machine is installed.

It's absolutely necessary to respect the phase polarity and the number order of wires and terminals.

Carry out the wire connections as per the wiring diagram attached to this manual (also refer to the copy of the wiring diagram placed into the electrical panel of the Machine).



COLD AIR – FPA KITCHEN 5.0
Section 3 – Protection Devices

WIRING DIAGRAM FOR CONNECTIONS

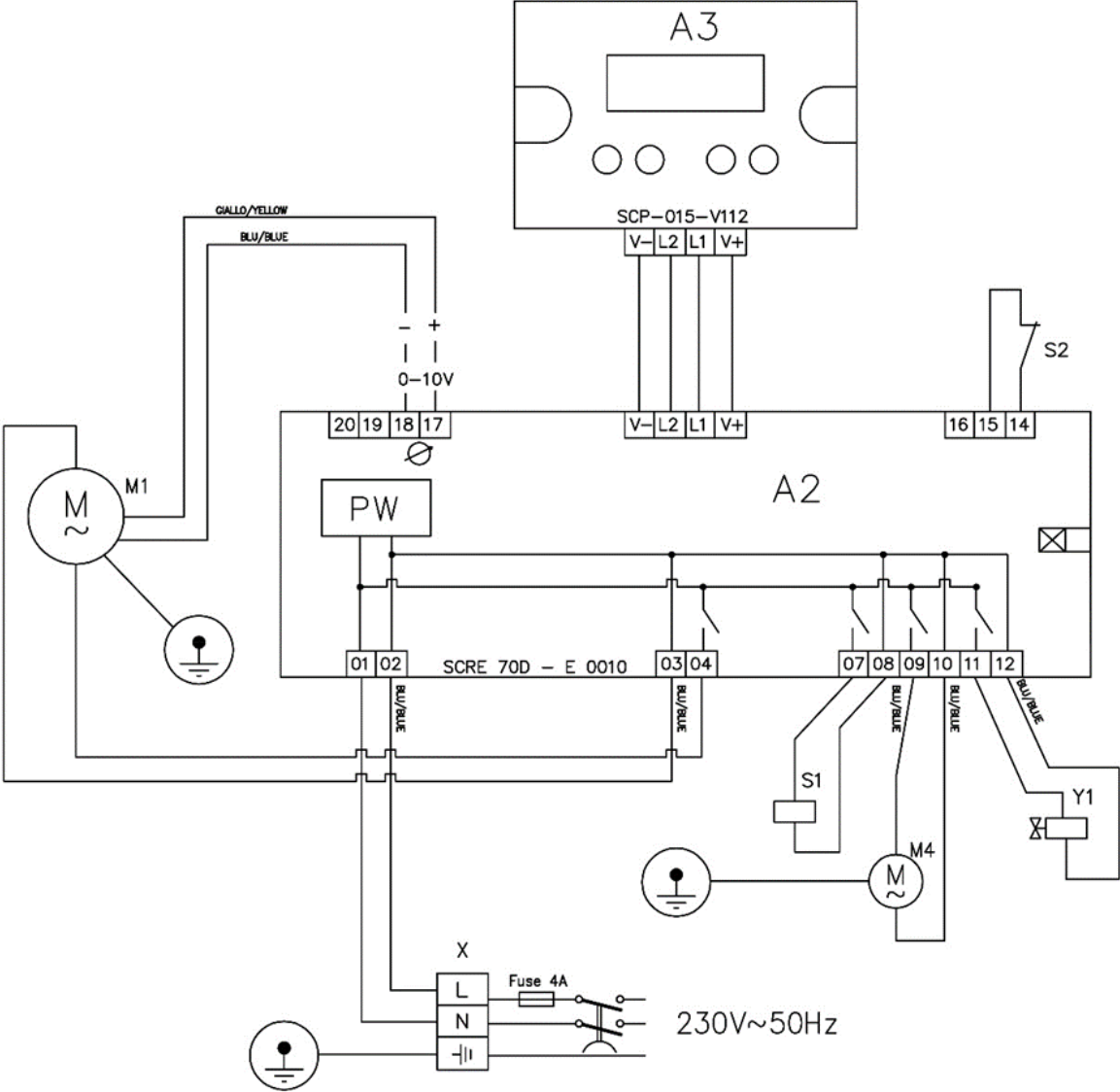

Legenda:

A2	MODULO DI POTENZA	PRINTED CIRCUIT BOARD
A3	MODULO DISPLAY	CONTROL CONSOLE
M1	VENTILATORE	FAN
M4	POMPA	PUMP
S1	SCARICO	DRAIN
S2	LIVELLOSTATO A GALLEGGIANTE	FLOAT REED
X	MORSETTIERA	TERMINAL BLOCK
Y1	ELETTROVALVOLA INGRESSO ACQUA	WATER INLET SOLENOID VALVE



COLD AIR – FPA KITCHEN 5.0 Section 3 – Protection Devices

Every **FPA.KITCHEN** is supplied with its display & control panel completely pre-wired and tested. The installer has only to connect the Machine to the power supply by removing, in sequence: as first, the base frontal panel (picture below), and then the cover of the electrical box. For power supply connection use the highlighted terminals.

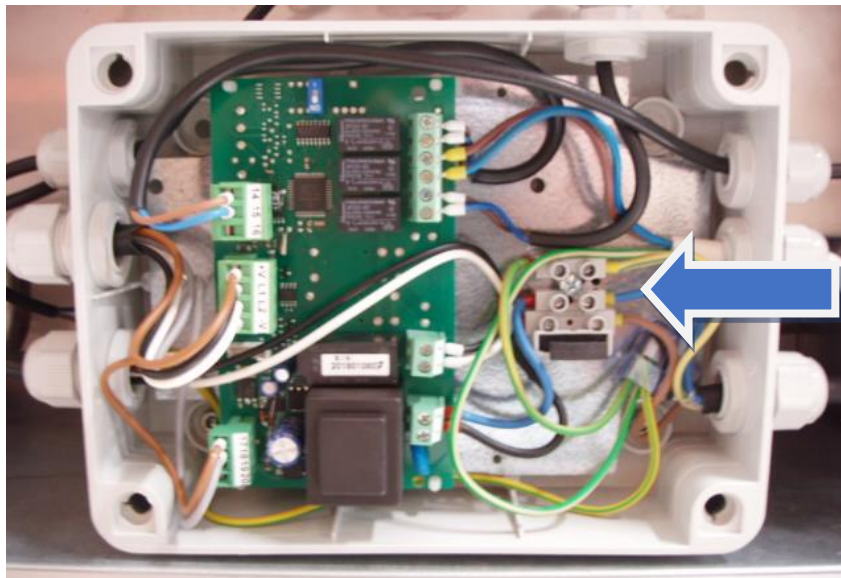
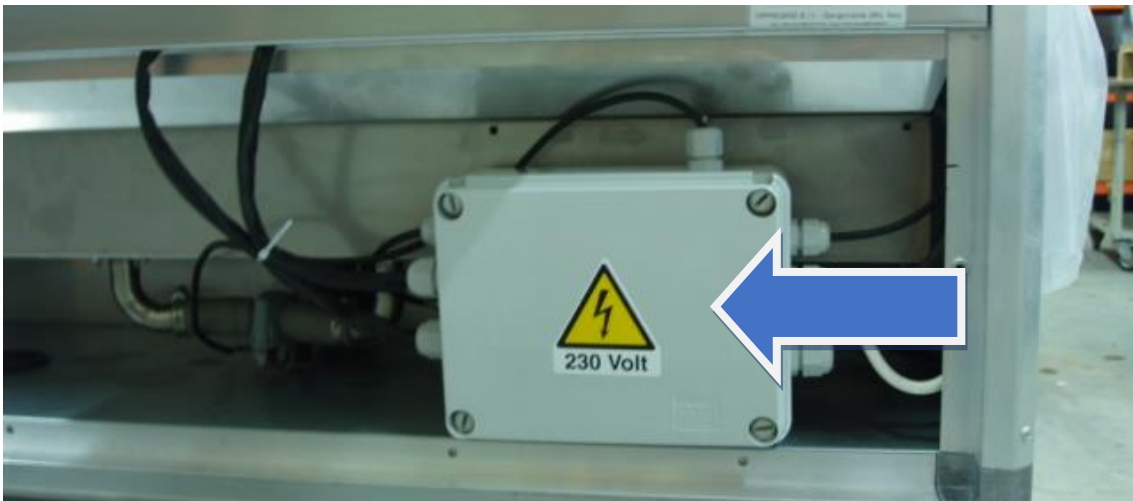
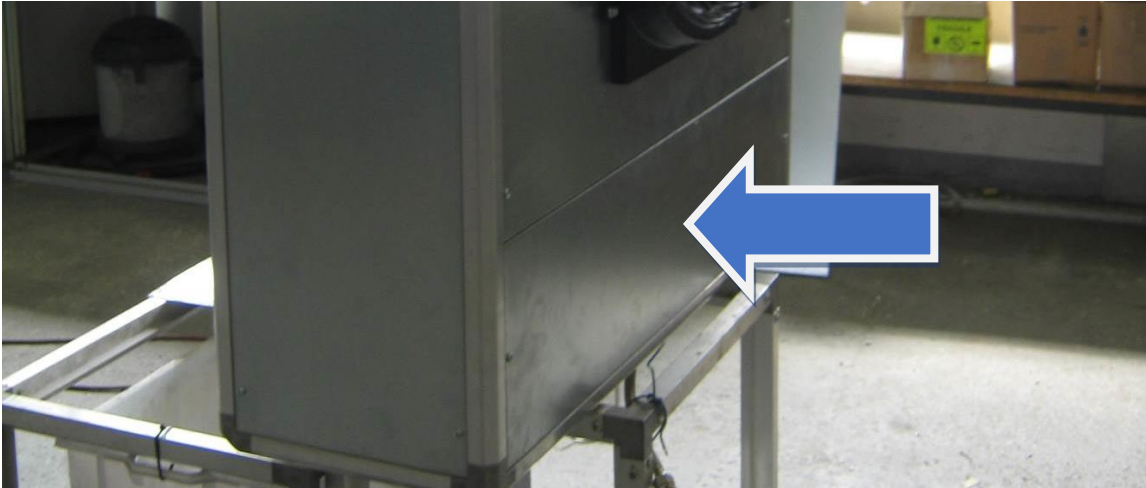



COLD AIR – FPA KITCHEN 5.0 Section 3 – Protection Devices

3.4 Connection to the water supply

For the water supply, the **FPA-KITCHEN** Air Cooler is equipped with a 3/8" water inlet connection, positioned in the lower part of the Machine.

The Customer must provide a water shut-off valve at the Machine inlet.

Together with **FPA-KITCHEN** Air Cooler **IMPRESIND SRL** supplies a special water filtration kit, to be installed before the water inlet valve.

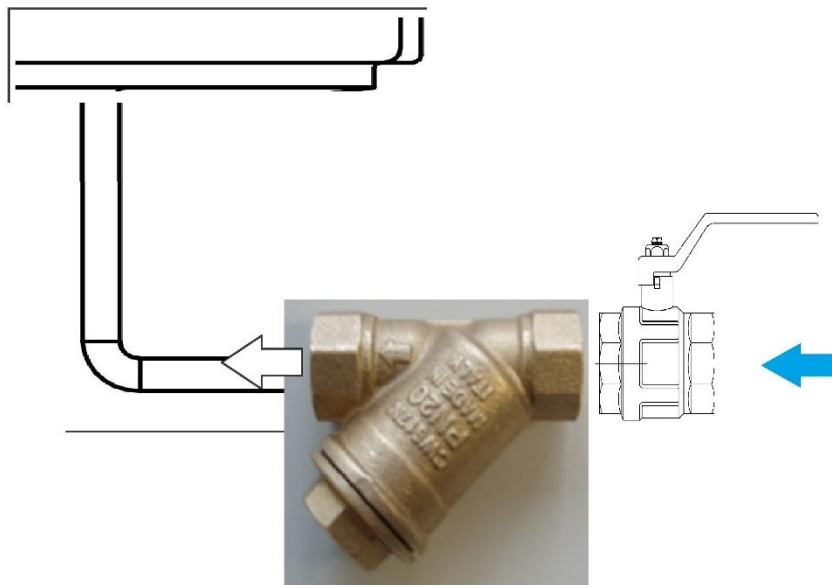

For a correct connection, please read the specific information sheet.

The water pipe must guarantee a minimum capacity of 5 -10 Litre/Minute, at a pressure of 1.5 - 3 bars (maximum pressure allowed: 6 bars).

It is advisable to have the water pipe installed inside the building, in order to protect it against freezing during winter. Provide for the possibility of emptying the water pipe; on contrary, provide for an adequate insulation.



ATTENTION

DO NOT use excessive force on the water inlet connection when connecting to the water supply system.





COLD AIR – FPA KITCHEN 5.0

Section 3 – Protection Devices

The Machine is equipped with a Diam. 22 mm hose for water discharge.
An additional flexible duct Ø22 for the water discharge is supplied with the machine.
The water discharge hose can exit the Machine from the bottom or from the back (see the picture below).
Connect the hose to the water discharge system according to the hygiene regulations in force in the country where the Machine is installed.



ATTENTION

When connecting the water discharge hose, to the discharge valve inside the Machine, make sure the connection is tight and sealed. To avoid leakages, use a metallic clamp strip.





SECTION 4 – PROTECTION DEVICES

4.1 Protection devices

To comply with the provisions contained in the Community Directives applicable to the machine to which this manual refers, IMPRESIND SRL has installed on the machine itself the safety and protection devices as provided by the regulations in force.

4.2 Work-clothing

The Machine is intended for installation in positions that cannot be directly reached by users during normal operations, and therefore particular prescriptions regarding work-clothing are not necessary.

Maintenance personnel must use suitable work-clothing and wear individual protection devices.

4.3 Residual risks



Pay attention to fan movement. Do not introduce arms or limbs.
Mechanical danger



It is forbidden to use water to clean electro-mechanical components.
Electrocution danger

4.4 Emergency situations



In case of emergency:
- stop the machine immediately and cut-off the electrical supply by switching off the omnipolar circuit-breaker.
- identify and eliminate the problem by tracing the causes that gave rise to the problem
- call the Service Technical Department at IMPRESIND SRL



IT IS STRICTLY FORBIDDEN TO USE WATER TO EXTINGUISH FIRE.
USE ONLY POWDER OR CARBON DIOXIDE FIRE EXTINGUISHERS.



COLD AIR – FPA KITCHEN 5.0 Section 5 – Operations

SECTION 5 – USE OF FPA-KITCHEN EVAPORATIVE COOLER

5.1 Control panel

The **FPA-KITCHEN** Air Cooler is equipped with a control panel with display that allows the various control operations:

- ON / OFF
- COOLING / VENTILATION MODE
- FAN SPEEDS

The Control Panel is equipped with a microcontroller that allows the possibility to set all the functions and parameters necessary to ensure a proper and good operation of the Machine (pre-cleaning – periodical panel cleaning - end cycle final washing); all these functions are needful for good running of the Machine.





COLD AIR – FPA KITCHEN 5.0 Section 5 – Operations

5.2 – Description of controls and signals

5.2.1 Control panel description

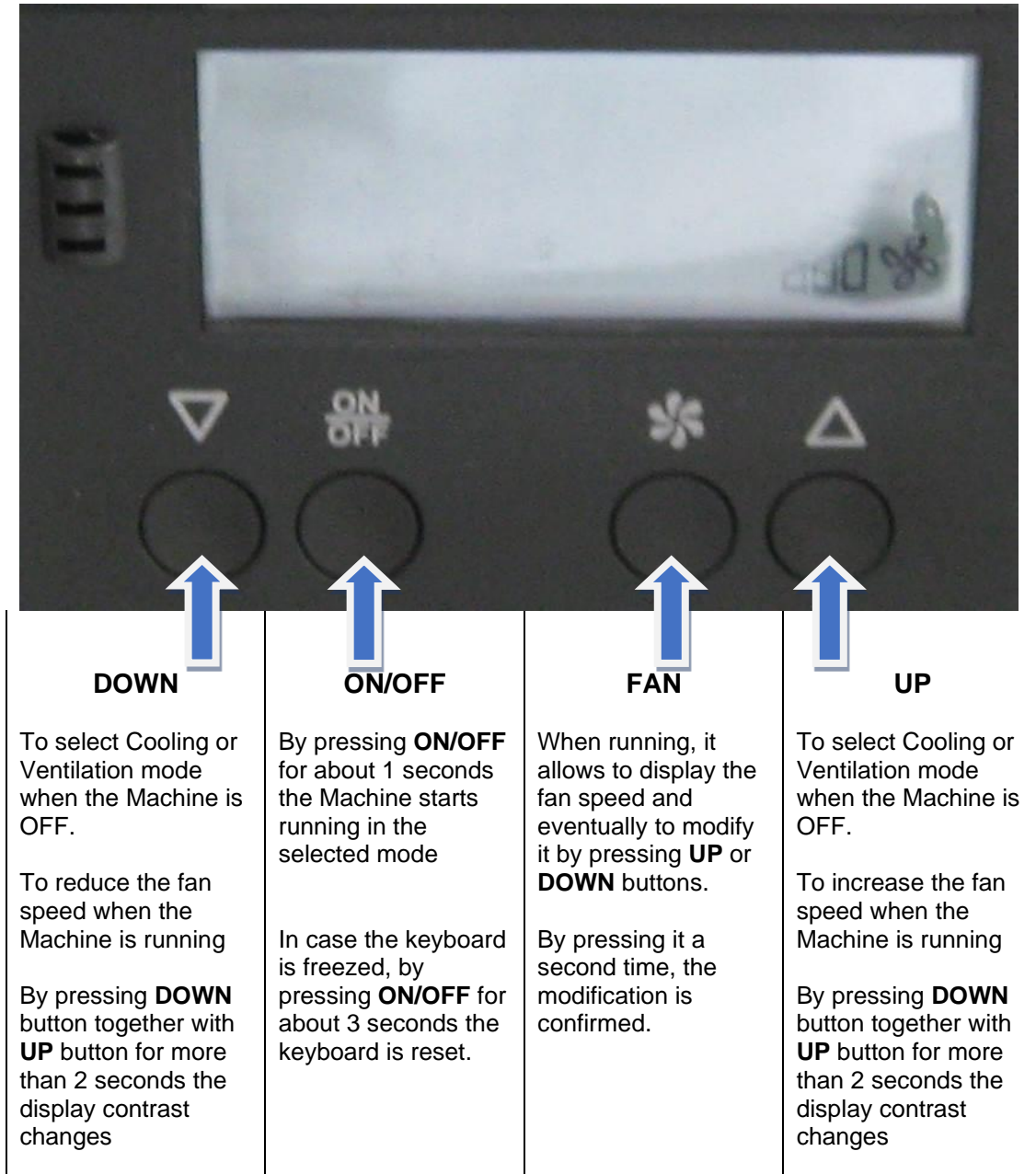

Please bear in mind that the Machine has to be always powered, even when it is switched-off or in stand-by, in order to allow the necessary final cleaning and washing.



COLD AIR – FPA KITCHEN 5.0 Section 5 – Operations

5.2.2 Signals description

In the middle of the display, the information related to the selected running mode are shown.

In the upper-right side of the display, the symbol of Cooling Mode will appear when cooling mode is selected.

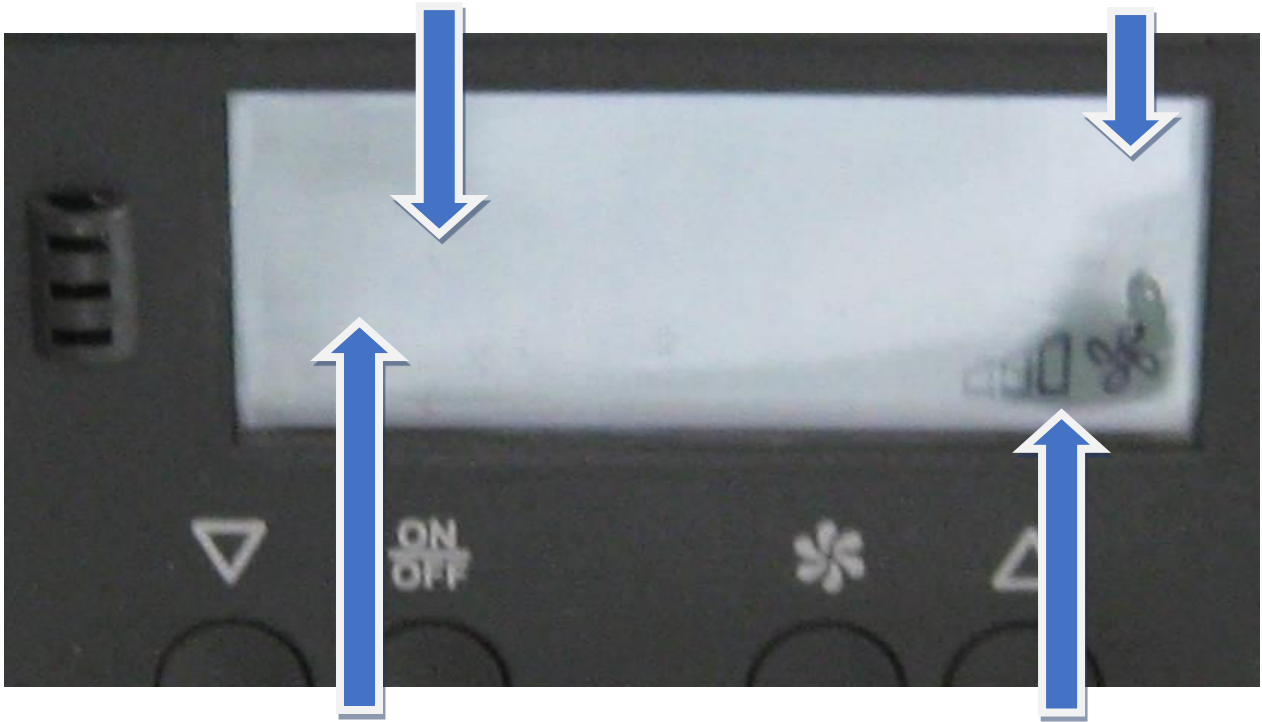

Here below the information that appears in the central part of the display:

OFF: The Machine is powered, but it is in stand-by mode, waiting for the start command.

COOL: the Cooling Mode is selected and the machine is running in cooling mode.

FAN: the Ventilation Mode is selected and the Machine is running in ventilation mode.

F1, F2, : information related to the selected fan speed.

Bar graph that indicates the actual fan speed.

This control device allows to select, and to display, up to 5 different fan speeds.

The different fan speeds are indicated by the change colour of the bar graph.



COLD AIR – FPA KITCHEN 5.0 Section 5 – Operations

5.4 Operation

When the Machine is powered, the word **OFF** appears in the middle of the display. Starting from that moment the Machine is powered but it is in Stand-by mode, waiting for the Ventilation mode or Cooling mode to be selected and confirmed.

To select a running mode, press **UP** or **DOWN** buttons. When the fan-blade icon appears in the upper right side of the display, the Cooling mode is selected; if nothing appears, then the Ventilation mode is selected.

In order to confirm the selected running mode, press the **ON/OFF** button, and then the machine starts. To stop the Machine, press the **ON/OFF** button.

WARNING!!! The control system does not allow to switch from Colling mode to Ventilation mode when running.
To change the running mode, it is mandatory to put the Machine in Stand-by and then select the new running mode.

WARNING!!! Before changing from Colling mode to Ventilation mode, make sure that the automatic processes of washing and final water discharge are finished.

ADDITIONAL INFORMATION ABOUT COOLING MODE

When the fan is running at the minimum speed and the control panel does not accept a new input selection, this is not a failure, but it is normal set of the control program. This means that in that specific moment the Machine is carrying out the evaporative panels wetting phase, in order to guarantee a good running of the cooling mode. This wetting phase procedure takes about 2 minutes.

5.5 Change of the circulating water

In order to avoid excessive concentration of salts, minerals, dirt and the possible formation of algae, at regular time intervals set by the installer (default time setting: 3 hours), the machine completely drains the water inside and then reload new water. During this phase fan runs at minimum speed.

5.6 Shut-down

To shut-down the Machine, press the **ON/OFF** button.



COLD AIR – FPA KITCHEN 5.0

Section 5 – Operations

5.6.1 Shutdown automatic washing cycle

With the Machine running in Cooling mode, every time the Machine is switched-off an automatic washing cycle is started, as follows:

- 1) The water contained in the Machine is completely discharged;
- 2) New clean water is loaded into the machine.
- 3) The new clean water is circulated through the panels to wash
- 4) After the panels washing, also this water is completely discharged from the Machine

This cycle lasts about 10 minutes.

Long downtime (end of season)

To shut-down the Machine and completely cut-off the electric supply, switch the omnipolar circuit-breaker to OFF position.

Before doing this, pay attention that the Machine is in Stand-by mode and that all the automatic cleaning and washing phases are completely finished.

It is advisable to wait at least 15 minutes before cutting-off the power supply.

Notes about the Machine operation

- To ensure an adequate cooling, the air introduced by the machine should be able to get out. For more detailed information refer to chapter 5.7 *Air Changes*.
- Don't start the Machine if it is not possible to evacuate the cold air introduced.
- The cooling efficiency is not only related to the Machine efficiency, but it depends also on different additional variables that are independent from the machine itself, like the room insulation, the room position, the external air condition, the air changes, etc.
- If the Relative Humidity of the outdoor air is high, the cooling efficiency and capacity is reduced.
- During the Cooling mode, the evaporative process produces an accumulation of salts and solid residues in the water, so **THIS EXHAUST WATER IS NOT DRINKABLE.**

5.7 Air changes

The evaporative cooler works on the basis of an important principle: it introduces large quantities of fresh and cooled air into the room and pushes-off hot exhausted air through openings like doors, windows or other evacuation openings.

The **ColdAir FPA-Kitchen** combines these above mentioned characteristic with an additional basic air filtration.

FRESH PURIFIED AIR ENTERING = HOT EXHAUSTED AIR EXITING



COLD AIR – FPA KITCHEN 5.0

Section 5 – Operations

If the system is in position to expel all the air introduced into the building, then the system is operating at the highest efficiency.

The ideal condition is to install the Machine far away from the openings (windows, doors, etc.), better on the opposite side, so that the air can pass through the whole room while cooling it. Never close the openings: if they are closed, no air changes will occur, consequently reducing the cooling effect and increasing the relative humidity level inside the room.

In case of professional kitchens, the air evacuation could be carried out through the existing suction hoods; the Installer shall check the air balancing between the air supplied by the Machine and the air evacuated through the extraction hoods, also considering the resulting pressure in the room.

The maximum efficiency can be reached by adjusting the opening of doors and windows. In order to optimize the system efficiency, consider the following openings for air evacuation:

0,5 sq.m. of evacuation opening per 1.000 cu.m. of air supplied
(refer to the project data)

Dryer is the external air more cooling capacity shall be reached by the Machine.

The evaporative cooling system does not operate at its maximum efficiency during high humidity days, even if it reaches an efficient cooling level.

In areas with high Relative Humidity, the evaporative cooling system must be oversized in order to guarantee more air changes or, in other words, it must have a higher capacity to compensate the smaller temperature difference obtained.

In these areas, the maximum cooling effect will be reached by making sure that there are more air evacuation points than normally used and that the machines are switched-on early in the morning to avoid latent heat growing up inside the space to be cooled.

Your supplier will design your system considering your climatic conditions.

During days when the Relative Humidity level is near to or more than 70%-75%, it is advisable to switch-on the system in Ventilation Mode only.

5.8 Commissioning and first start-up



ATTENTION:

For a correct and optimal operation and use of the Machine it is essential that, at the time of the first start-up in Cooling Mode, the fan is set at minimum speed and this minimum speed is kept for at least one full day.

The non-execution of the aforementioned procedure could cause, limited for the first day of use only, a malfunction of the evaporating panels with consequent water drops blowing out from the Machine.

During the commissioning of the Machine, an unusual smell might be noticed.

When the evaporating panels begin to get wet, they could emit a peculiar smell that could last for a few hours. This smell is typical of the treated cellulose materials but is not harmful.



COLD AIR – FPA KITCHEN 5.0

Section 5 – Operations

Even the fan motor could release an unusual smell, for a short period; this is caused by the initial heating and by the presence of paint residual particles on the surface of the motor itself.

5.9 Seasonal stop

At the end of the operation period, the Machine has to be stopped by switching the omnipolar general circuit-breaker in OFF position.

At this point, it is recommended to carry out the ordinary maintenance operations so to keep the Machine clean during the winter.

WARNING: Do not carry out any maintenance operation when the Machine is connected to the power supply!

5.10 Operation anomalies

Here below a list of the most common operation anomalies:

The water pump does not provide a correct wetting of the evaporative panels	This could be caused by a residual dirt in the water circuit. Check the water circuit, and clean / remove any obstruction or dirt accumulation
Not homogeneous wetting of the evaporative panel	This could be caused by water with high hardness level which caused the clog some holes of the water wetting system
Floating stuck	This could happen in case of strong shocks during handling
Abnormal increase of water consumption	This could be cause by a problem in the discharge valve, especially if it is partially or completely obstructed. In that case the water will start to flow away from the Machine through the drain hose.

In the event of any malfunction:

1. Switch-off the Machine
2. Cut-off the power supply
3. Close the water supply valve
4. Contact the company who carried out the installation of the Machine or a qualified technician



COLD AIR – FPA KITCHEN 5.0
Section 5 – Operations

5.11 Safety signs onboard the Machine



ELECTRICAL HAZARD ⇒ Risk of electric shock due to components connected to power line.



SECTION 6 – MAINTENANCE

6.1 End-season maintenance

At the end of each season, in order to provide a proper maintenance, to preserve and protect the Machine during the stopping period and ensure a correct start up and functionality for the next season, it is strongly recommended to carry out the following operations:

- 1) Cut-off the power supply by switching the omnipolar circuit-breaker in OFF (this is the first mandatory step to ensure the safety during all the maintenance activities)
- 2) Close the water supply valve
- 3) Drain and empty the water supply pipe to avoid cracks due to icing
- 4) Clean the water filter (view the apposite information sheet)
- 5) Remove the front panel of the Machine
- 6) Check that the pipes inside the Machine are clean and that there are no obstructions in the water supply and distributor in the upper part of the Machine. Clean any debris in the water pump
- 7) Carefully clean the internal bottom of the Machine. Use a mild detergent, don't use any solvent because it may react with the plastic materials.
- 8) Put back in place the front panel, make sure it is properly installed and check the bolts tightening.

6.2 Pre-season maintenance

In order to keep and preserve the Machine in perfect working conditions, it is recommended a maintenance intervention before the Machine is started:

- 1) Cut-off the power supply by switching the omnipolar circuit-breaker in OFF (this is the first mandatory step to ensure the safety during all the maintenance activities)
- 2) Remove the front panel of the Machine
- 3) Clean the internal bottom of the Machine from any dirt, debris accumulation
- 4) Put back in place the front panel
- 5) Clean the water filter (view the apposite information sheet)
- 6) Open the water supply valve. Start the Machine in Cooling Mode and check that the drain valve is closed. Wait for the Machine pump to start
- 7) Check the water drops down on all the evaporative panels and make them wet in a homogeneous way
- 8) Check the drain valve works in a correct way by pressing the OFF button on the control panel and make sure that the valve opens within 5 minutes.



COLD AIR – FPA KITCHEN 5.0 Section 6 – Maintenance

6.3 Maintenance safety norms



***The maintenance personnel must be professionally qualified.
Before carrying out any maintenance operation, read carefully this section of the manual.***

For any need, contact the Technical Assistance Service at IMPRESIND SRL..

IMPRESIND SRL is not responsible for any damage or malfunctions due to lack of respect of the indications contained in the present manual.

The personnel in charge of maintenance of the Machine must not wear clothing with large sleeves, laces or belts, which may cause hazard. Furthermore, the personnel must also wear all necessary individual protection devices as per the laws and regulations in force.

Before putting the Machine into operation it is necessary to check that the Machine is running correctly, so that any needed maintenance and/or repair can be carried out before its operating period.



IMPRESIND SRL does not assume any responsibility or is liable for any warranty due to damage caused by the non-observance of prescriptions, any non-conform installations and in the case of improper use of the Machine by the final user.

During maintenance operations, make well and easily visible on all access areas to the department a sign stating “Work in Progress”.

Record, on an appropriate register, all maintenance interventions carried out and make sure to state the following information:

- date - time - type of intervention performed - name of the technician.

It is reminded solvents are not allowed in cleaning operations to avoid any damage to the electrical cables.



The personnel in charge of maintenance that uses any solvent must be equipped with Individual Protection Devices (safety glasses, filter masks, gloves) suitable for contact with the solvent used.

***When using solvent, it is strictly forbidden to smoke and use open flames.
After use, ventilate the building to help any residual vapours to leave.***



COLD AIR – FPA KITCHEN 5.0
Section 6 – Maintenance



It is forbidden to:

- Leave any flammable material near to the electrical panels.***
- Work on the electrical equipment without isolating the equipment from the power supply lines.***
- Work on any part of the Machine before the plant has come to a stop.***
- Operate the Machine with the safety systems deactivated or removed.***
- Deactivate or evade the alarm signals.***
- Ignore the warning signals and signs applied on-board the Machine***
- Operate the Machine with the metallic protections removed.***

Once the maintenance is finished, before turning the power back on and starting the machine, carefully check that any tool and / or material of any nature has not been left near or inside the machine and, above all, close to any movement mechanism.



COLD AIR – FPA KITCHEN 5.0 Section 6 – Maintenance

6.4 Replacement of the evaporative panels

To ensure a good cooling performance and efficiency, the panels must be clean and in good condition.

Before starting the Machine for a new season, it is recommended to check the conditions of the evaporative panel. The average lifetime of the evaporative panels is not defined because it depends on several variables such as the effective working hours, the water hardness level, the position of the Machine and the installation environment.

The evaporative panel can be disassembled / replaced from the front of the Machine as well from the side, as shown below.

FRONT ACCESS

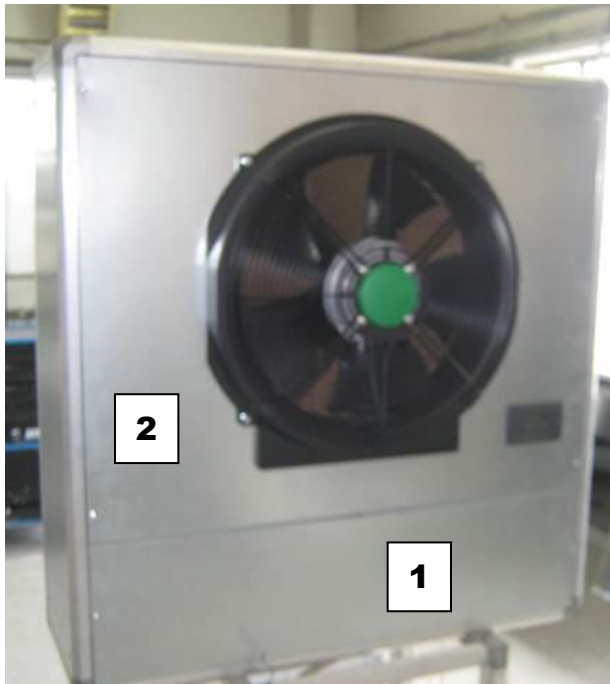

To open the front panel and access the evaporative panel:

- remove the lower front panel (1)
- disconnect the wires connections among the electric enclosure and the fan and command display.
- remove the upper front panel (2) caring about the fan and the control display to avoid to damage them.
- the evaporation panel is now accessible and it can they be easily removed

SIDE ACCESS



To open both sides panels and access the evaporative panel:

- remove the sides panels (3)
- the evaporation panel is now accessible and it can they be easily removed

NOTE

It is recommended to access and remove the evaporative panel from the left side of the Machine, as indicated in the picture.

Removing the evaporative panel from the right side is possible, but it could result more difficult due to the presence of the water supply system.



COLD AIR – FPA KITCHEN 5.0 Section 6 – Maintenance

Before dismounting and extracting the evaporation panels it is necessary to unscrew and remove the upper metal strip as shown in the attached picture.

Then it is possible to remove the water distribution strip and extract the evaporation panels once per time.

Start to remove the panel at the opposite side of the pump and then slide the second panel and remove it too.

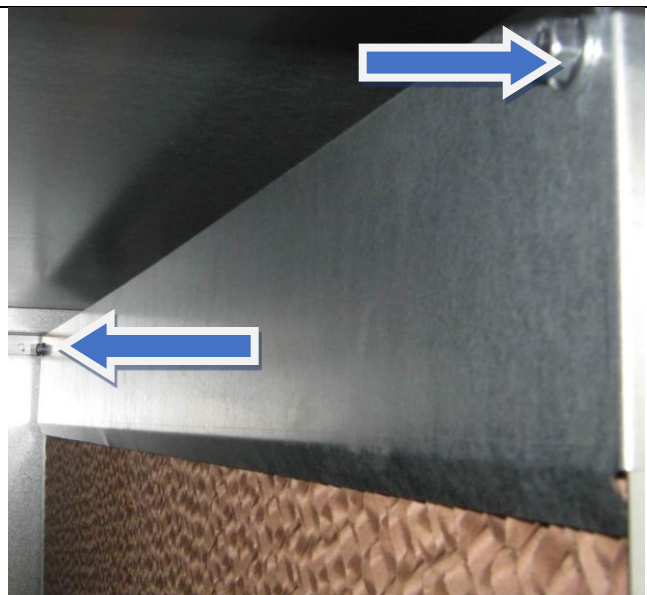

6.5 Technical assistance request

For any request of technical assistance intervention, contact the installer or eventually contact the Technical Assistance Service of IMPRESIND SRL

Production Headquarters:

Via Primo Maggio 24, 20064 Gorgonzola – Milano (ITALY)

☎ +39 02 9574.1932

📠 +39 02 9574.0637

✉ info@impresind.com

🌐 www.impresind.com



COLD AIR – FPA KITCHEN 5.0 Section 7 – Disassembly

SECTION 7 – DISASSEMBLY

7.1 Putting out-of-service



Disassembly of the Machine must be carried out by specialized personnel, equipped with suitable equipment and personal individual protection devices. Do not smoke and do not use open flames.

In the case of disassembly and disposal of the plant, all materials that makes up the plant must be collected and sent to the appropriate collection and disposal centres, better by contacting companies specialized in equipment disposal.

INFORMATION FOR REMOVAL OLD MACHINES



Attention:

This product falls within the scope of the Directive 2012/19/EU concerning the management of waste electrical and electronic equipment.

This device is for professional use only; so it must not be disposed of with domestic waste, as it is made of different materials that can be recycled at the appropriate structures.

This product is not dangerous for human health, but if abandoned in the environment negatively impacts on the ecosystem.

Read the instruction before using the device, and don't use this product for any use other than that indicated in the instruction.



This symbol mean that this product is part of the legislation on the waste electrical and electronic equipment.

Abandonment in the environment of the device , or illegal disposals, is punishable by law.



COLD AIR – FPA KITCHEN 5.0
Section 8 – Technical Drawings

- ALIMENTAZIONE/ELECTRIC SUPPLY: 230V 50Hz
- POTENZA ELETTRICA /ELECTRIC POWER: 0.45 kW
- PORTATA ARIA/AIR FLOW: 5.000 m³/h
- PESO (a carico)/WEIGHT (full): 100 kg
- PESO (a vuoto)/WEIGHT (empty): 70 kg
- SUPERFICIE EVAPORANTE/EVAPORATING SURFACE: 0.7 m²

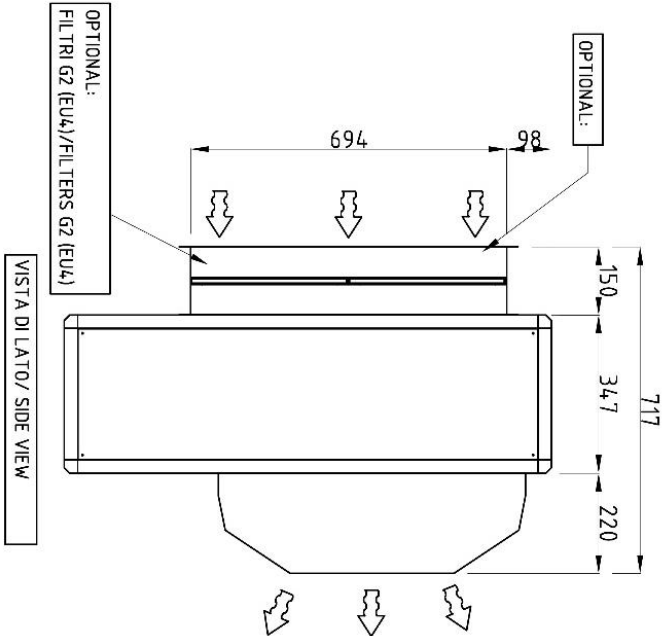
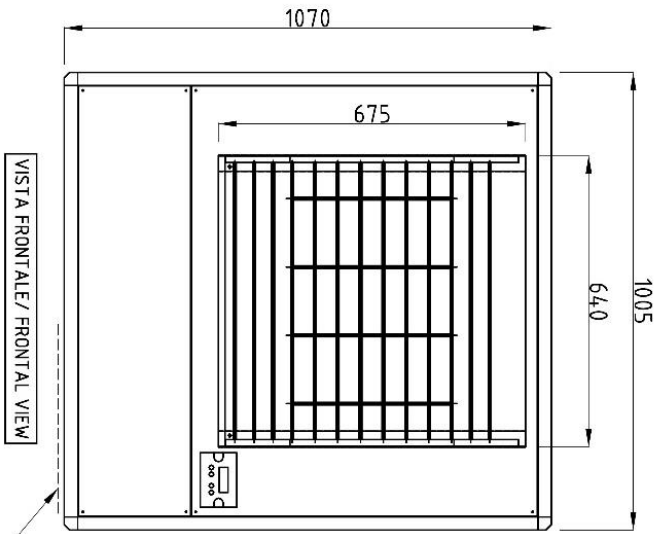

- LATO UTENZE/UTILITY SIDE
- TROPPO PIENO/ MAX WATER LEVEL DRAIN
 - SCARICO ACQUA/WATER DRAIN
 - CARICO ACQUA/ WATER LOADED
 - ALIMENTAZIONE ELETTRICA/ELECTRIC SUPPLY
- Ø 22
3/4"

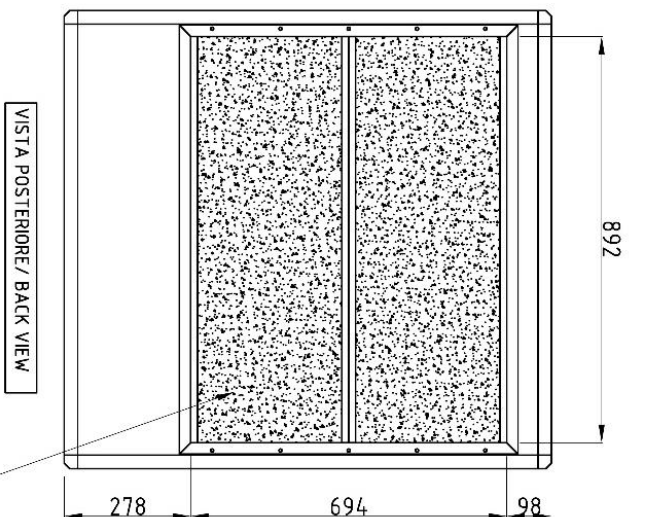

<p>impresind s.r.l. zedda, Giamparola Via Italia 10138 SASSUOLO (TV) - Tel. 0422/551407</p>		<p>Modello: FPA-KITCHEN-5.0</p> <p>Versione: I (039)</p>	
<p>Descrizione: FPA-KITCHEN-5.0</p>		<p>Accessori: FPA-K-5000A(G2)</p>	
<p>Caratteristiche tecniche:</p>		<p>Dimensioni:</p>	
Altezza	1005	Profondità	675
Larghezza	1070	Spessore	98
<p>Portata d'aria (a vuoto): 5000 m³/h</p>		<p>Peso (a vuoto): 70 kg</p>	
<p>Potenza elettrica: 0.45 kW</p>		<p>Consumo elettrico: 0.45 kW</p>	
<p>Superficie evaporante: 0.7 m²</p>		<p>Classe energetica: A</p>	



IMPRESIND SRL

Via Primo Maggio 24, 20064 Gorgonzola – Milan (ITALY)

☎ +39 02 9574 1932 📠 +39 02 9574 0637 ✉ info@impresind.com

www.impresind.com