INSTALLATION, OPERATION & SERVICE MANUAL

SWC - V - EC - I

SURFACE MOUNTED HIGHWALL
V - 2 pipe



Table of Contents

A. Installation	2
<i>A.1. Safety Precautions</i>	<i>2</i>
<i>A.2. Before Installation</i>	<i>3</i>
<i>A.3. Mounting Plate Dimensions</i>	<i>4</i>
<i>A.4. Mounting Plate Installation</i>	<i>5</i>
<i>A.5. Condensate Drainage Hole Drilling</i>	<i>5</i>
<i>A.6. Hydronic Unit Installation</i>	<i>6</i>
<i>A.7. Drainage Piping Works</i>	<i>6</i>
<i>A.8. Pipe Connections with Valve</i>	<i>7</i>
B. Control Specifications	8
<i>B.1. Wiring Diagram</i>	<i>9</i>
<i>B.2. Control Logic Specifications</i>	<i>10</i>
<i>B.3. Sleep Mode</i>	<i>14</i>
<i>B.4. Auto Fan Speed</i>	<i>14</i>
<i>B.5. Stepping Motor</i>	<i>14</i>
<i>B.6. Buzzer</i>	<i>15</i>
<i>B.7. Auto Restart</i>	<i>15</i>
<i>B.8. On/Off Switch</i>	<i>15</i>
<i>B.9. Electric Heater Safety Switch</i>	<i>15</i>
<i>B.10. Low Temperature Protection of Indoor Coil in Winter</i>	<i>15</i>
<i>B.11. Open Modbus Protocol</i>	<i>16</i>
<i>B.12. LED Display and Error Descriptions</i>	<i>19</i>
C. Master Slave Network Setup	20
D. User Interface	21
<i>D.1. Remote Handset</i>	<i>21</i>
<i>D.2. Wall Pad</i>	<i>22</i>
E. Maintenance	25
<i>E.1. Opening and Closing of Lift-Up Grille Cover</i>	<i>25</i>
<i>E.2. Front Cover Assembly Removal</i>	<i>25</i>
<i>E.3. Air Vent and Water Purge Valves</i>	<i>25</i>
<i>E.4. Wiring Connections</i>	<i>25</i>
F. Troubleshooting Guide	26

A. Installation

A.1. Safety Precautions

- When installing, performing maintenance or servicing Polar Air fan coil units observe the precautions stated in this manual as well as those stated on the labels attached to the unit.
- Ensure all local and national safety codes, laws, regulations, as well as general electrical and mechanical safety guidelines are followed for installation, maintenance and service.
- The appliance is for indoor use only.
- Ensure the correct power supply is provided.
- If the power supply cord is damaged, it must be replaced by qualified personnel.
- Installing and servicing fan coil unit should be performed by qualified service personnel only.
- This appliance is not intended for use by persons (including children) with reduced physical, sensory or mental capabilities, or persons lacking in experience and knowledge of the appliance, unless they have been given supervision or instruction concerning it.
- User of this appliance is responsible for his/her own safety.
- Warranty shall be voided if installation instructions and safety precaution stated in this manual are not observed.
- The unit should only be switched off by using the ON-OFF button on the control interface.

CAUTIONS

Before any service or maintenance operations turn off the mains electrical supply.

DO NOT turn OFF the main power supply when the unit is operating. Turn off the unit BEFORE turning off the main power.

A.2. Before Installation

Select the location for the high-wall unit with the following considerations:

1. The air inlet and outlet area should be clear without obstructions. The air should flow freely.
2. The high wall unit should be mounted on solid wall.
3. The location should allow easy access to connect water pipes easily achieve drainage.
4. Ensure the clearance around the fan coil unit conforms to the following drawing.

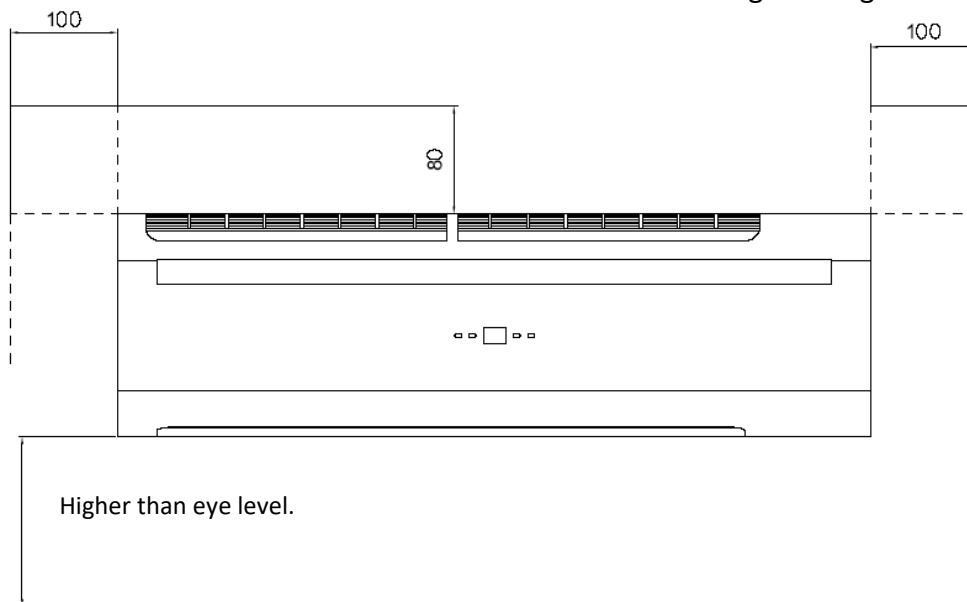

* Required clearance for maintenance and servicing is as shown above.

** All dimensions shown in mm.

5. The unit should be installed higher than eye level.
6. Avoid installing the unit with direct sunlight.
7. The signal receiver on the unit must be kept away from any high frequency emission source.
8. Keep the unit away from fluorescent lamps, which may affect the control system.
9. Avoid electromagnetic control system interference, ensure control wires are installed separately from 110-240 VAC power supply wires.
10. Use shielded sensor cables in where electromagnetic waves present,
11. Install a noise filter if the power supply creates any disruptive noises.

A.3. Mounting Plate Dimensions

SWC-12/15/18-EC-I

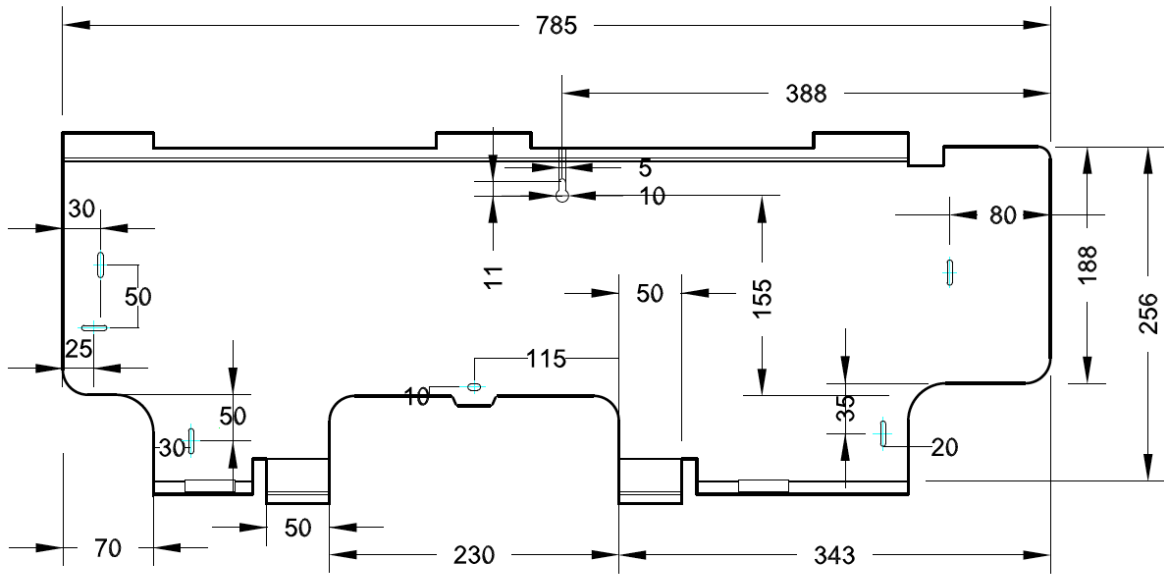

SWC-24-EC-I

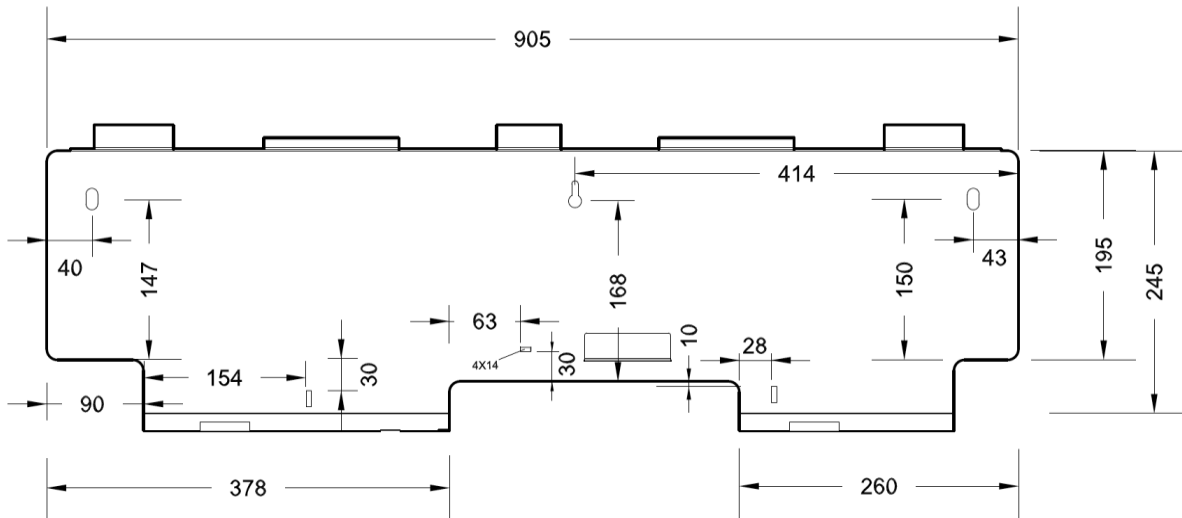

(All dimensions shown in mm)

A.4. Mounting Plate Installation

1. Select the structural position (e.g. a pillar or lintel) on the wall.
2. Then temporarily fasten the mounting plate on the wall with a steel nail.

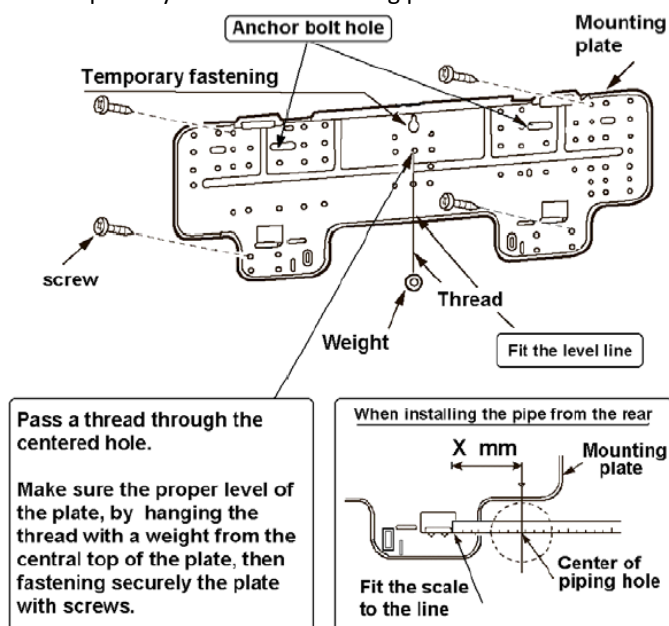

3. Mount the mounting plate horizontally as shown in the above figure or by means of gradiometer. Failed to follow this may cause water to drip indoors and create atypical noise.
4. Fix the mounting plate by means of expansion screws or tapping screws.

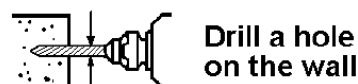

A.5. Condensate Drainage Hole Drilling

1. Ensure that the hole for condensate drainage is correctly positioned. The height should be lower than the bottom edge of the indoor unit.
2. Drill a 65mm diameter hole with a descending slope.
3. Seal it off with putty after installation.

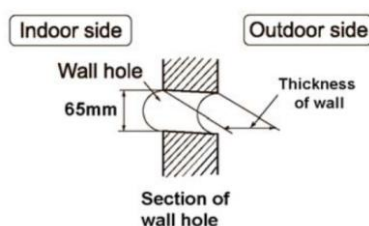

A.6. Hydronic Unit Installation

1. Pass the piping through the hole in the wall and hook the indoor unit on the mounting plate by the upper hooks.
2. Move the body of the unit from side to side to verify if it is securely fixed.
3. While pushing the unit toward the wall, lift it slightly from beneath to hook it up on the mounting plate by the lower hooks.
4. Make sure the unit firmly rests on the hooks of the mounting plate.

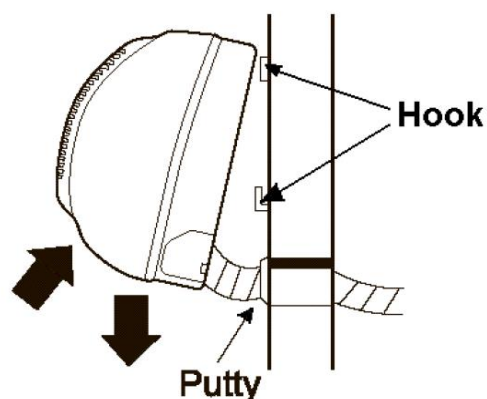

A.7. Drainage Piping Works

1. Install the drain hose so that it slopes downward slightly for free drainage. Avoid installing it as shown in the below illustrations marked with an "X".

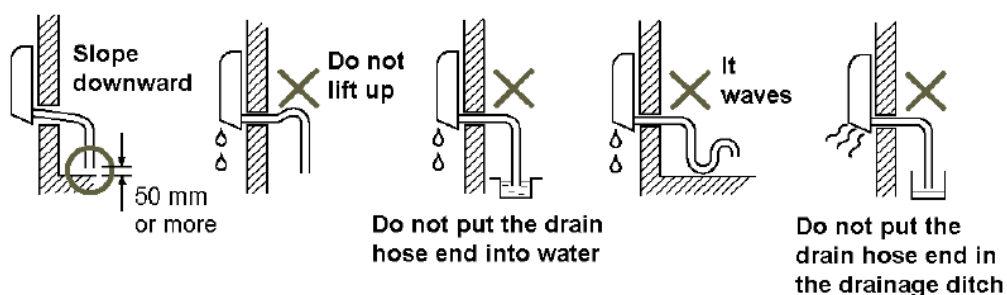

2. Put water in the drain pan and make sure that the water drains outdoors.
3. If the flexible drain hose provided with the indoor unit is not long enough, please extend it by joining it to an extension hose (not provided). Be sure to insulate the connecting part of the extension drain hose with a shield pipe as shown.

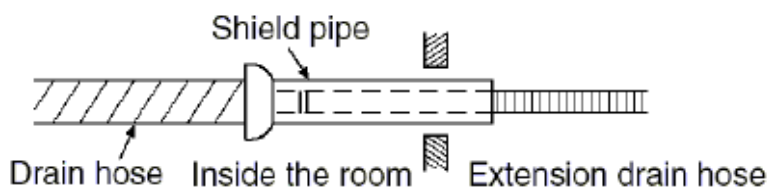

4. If the attached drain hose passes through an indoor area, insulate it with heat insulation material.

A.8. Pipe Connections with Valve

Pre-assembly

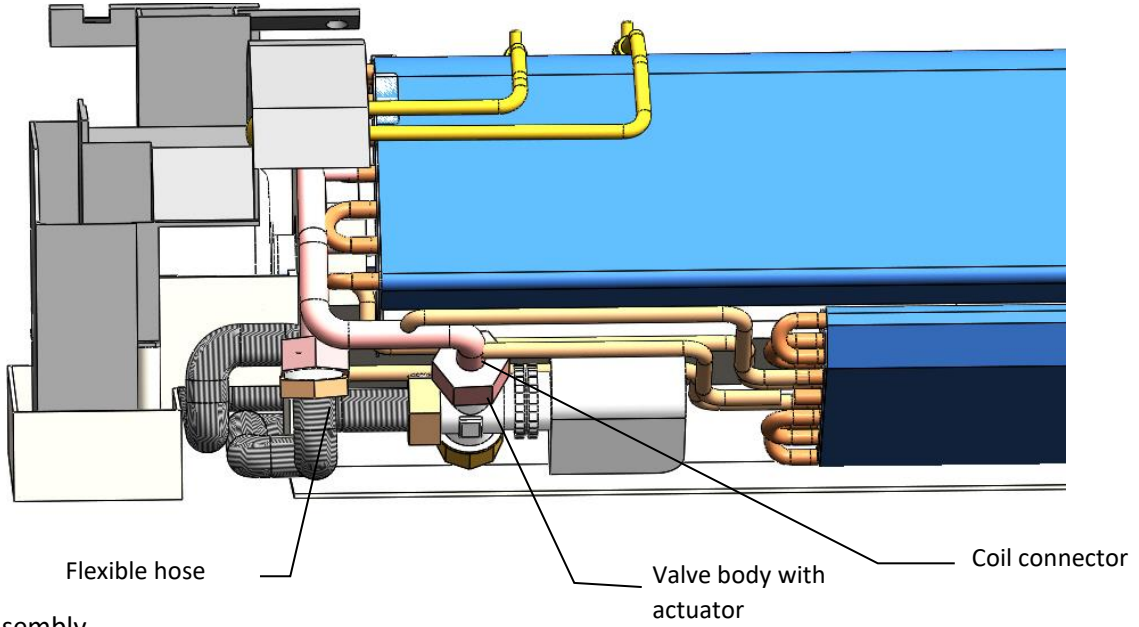

Complete Assembly

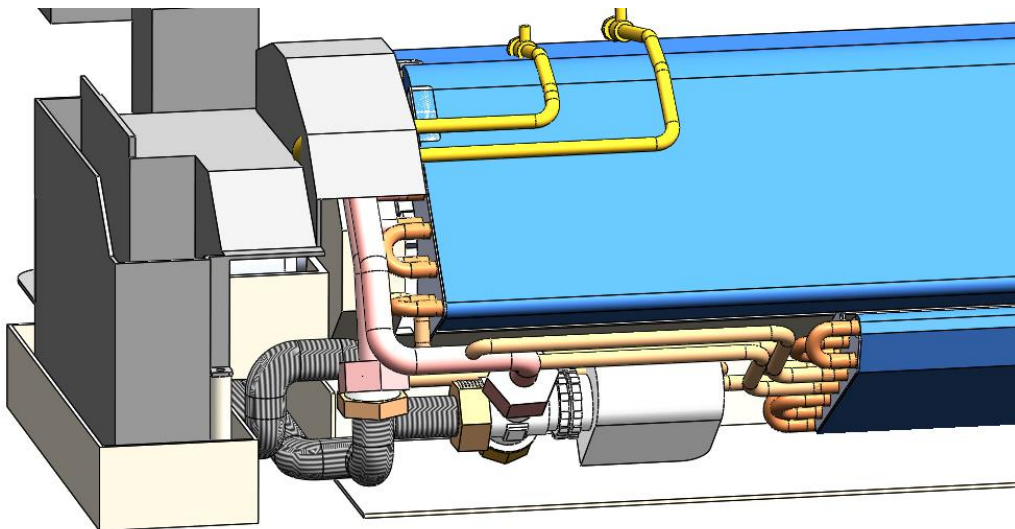

B. Control Specifications

I/O Port Definitions

Abbreviations

Ts = Setting temperature

Tr = Room air temperature

Ti1 = Water inlet temperature

Ti2 = Water outlet temperature

AUX1 = Cooling water free contact

AUX2 = Heating water free contact

V1 = Cooling water on/off valve

V2 = Heating water on/off valve

I/O		Code	2-Pipe
Analogue Input	Return air Sensor	AI1	Return air temperature (Tr)
	Chilled water Sensor	AI2	Water inlet temperature sensor (Ti1)
	Hot water Sensor	AI3	Water outlet temperature sensor (Ti2)
Input	IR receiver	X-DIS 1	Digital communication port to LED display/IR receiver board.
	Wired wall pad	TTL1	Digital communication port to wired wall-pad board.
Digital input	Occupancy contact	ON/OFF	NO/NC contact by setting
	Float switch	Float	Voltage-free (NC). The contact is connected with float switch (NC).
	Electrical heater safety switch	EH	Voltage-free (NC). The contact is connected with E-heater.
Power input	Phase	L	Power supply to the PCB;
	Neutral	N	Power supply to the PCB;
	Earth	G	Power supply to the PCB;
Voltage output	Fan 1	CN4	Fan 1 driver
	Valve1	V1	On/off valve
	Valve2	V2	On/off valve
	Water pump	WP	Voltage output (L), Power supply to condensate pump.
	Electric heater	Heat	Voltage output (L), maximum 10A.
Output	Stepping motor	CN1, CN2	Power supply to louver stepping motors.
	Cooling free contact.	AUX1	Voltage free contact. Maximum load 5A.
	Heating r free contact.	AUX	Voltage free contact. Maximum load 5A.
	Modulating valve control	DA1	0~10Vdc for cooling water modulating valve control
	Modulating valve control	DA2	0~10Vdc for heating water modulating valve control
	In Modbus signal	AB	Terminals for local network serial connection
	Out Modbus signal	AB	

B.1. Wiring Diagram

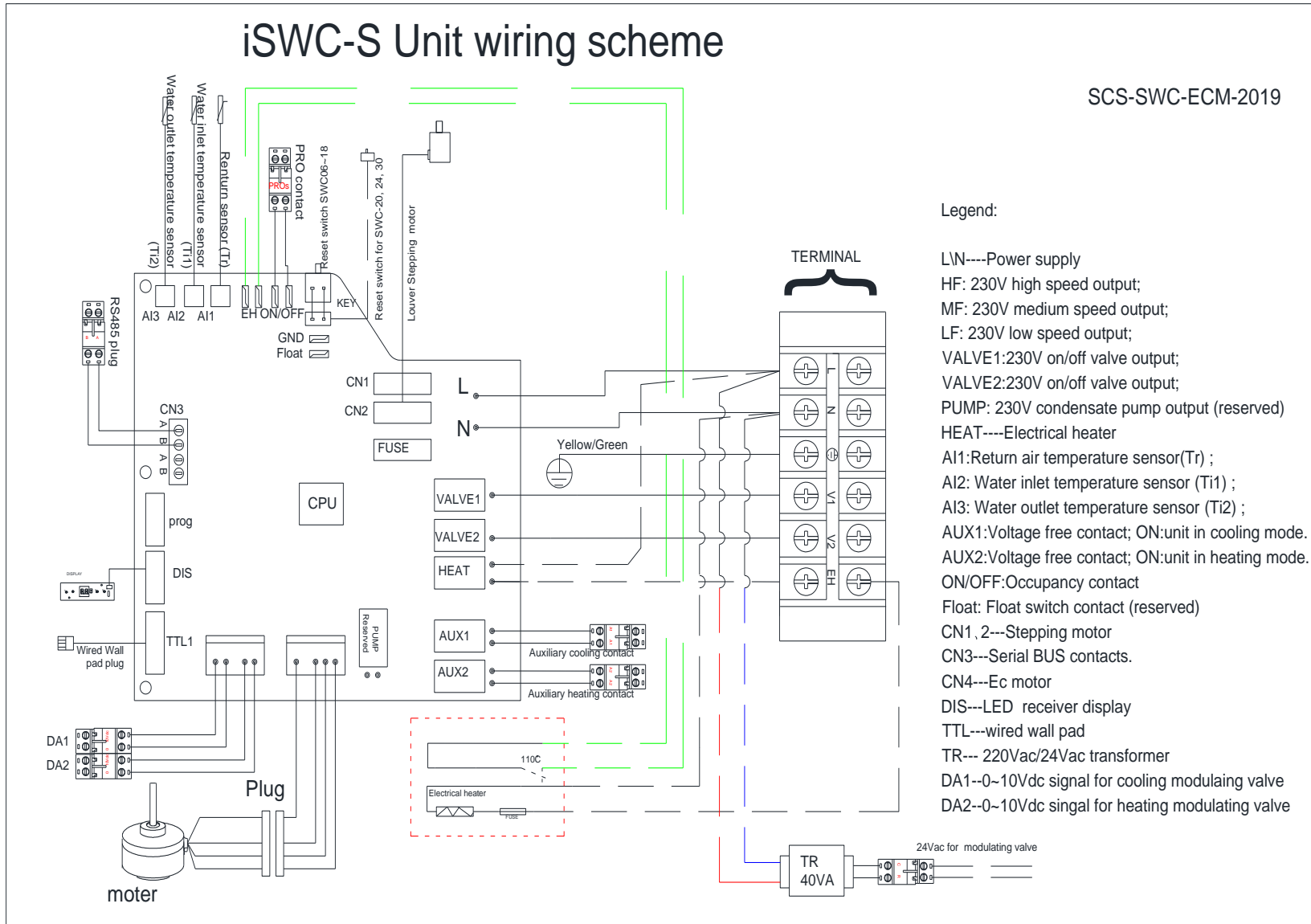

B.2. Control Logic Specifications

Fan Coil Unit ON/OFF

There are 3 ways to turn the system on or off:

- By the ON/OFF button on the remote handset or wired wall pad.
- By the programmable timer on the handset or wired wall pad.
- By the manual control button on fan coil unit.

Auto Restart

The system uses a non-volatile memory to save the present operation parameters when the system is turned off or in case of system failure or cessation of power supply.

The restored parameter data-set depends on the type of user interface.

- Handset only user interface:

When the power ON signal is received by the fan coil unit and no wired wall-pad is installed, the Mode, Fan Speed, set temperature will be the same as the handset setting before the last power OFF.

- Wall-pad only OR wall-pad and handset user interface:

When the power ON signal is received by the fan coil unit and a wired wall-pad is installed, the Mode, Fan Speed, set temperature and Timer ON/OFF weekly program will be the same as the wall pad setting before the last power OFF.

2-pipe Control Logic - with Modulating Valve

COOL MODE

When unit is turned on in cooling mode:

- If $T_r \geq T_s + 1^\circ\text{C}$ (Modbus 300033 setting), MTV1 is turned on. AUX1 is closed. Fan is turned on at setting speed.

DA1 is turned on at 10VDC for 2 minutes, then check T_{i1} :

When $T_{i1} \leq 8^\circ\text{C}$, DA1 output is based on water temperature difference (T_{i1}/T_{i2}) and Modbus parameter 300027 setting PID calculation. The output is the minimum output (Modbus300015 setting) $\sim 10\text{VDC}$.

When $8 < T_{i1} \leq 10^\circ\text{C}$, DA1 output is based on water temperature difference (T_{i1}/T_{i2}) and Modbus parameter 300027 setting minus 1 PID calculation. The output is minimum output (Modbus300015 setting) $\sim 10\text{VDC}$.

When $10 < T_{i1} \leq 12^\circ\text{C}$, DA1 output is based on water temperature difference (T_{i1}/T_{i2}) and Modbus parameter 300027 setting minus 2 PID calculation. The output is minimum output (Modbus300015 setting) $\sim 10\text{VDC}$.

When $12 < T_{i1} \leq 15^\circ\text{C}$, DA1 output is based on water temperature difference (T_{i1}/T_{i2}) and Modbus parameter 300027 setting minus 3 PID calculation. The output is minimum output (Modbus300015 setting) $\sim 10\text{VDC}$.

When $15 < T_{i1} \leq 28^\circ\text{C}$ (Modbus 300017 setting), DA1 output is kept at 10VDC.

When $T_{i1} > 28^\circ\text{C}$ (Modbus 300017 setting), DA1 output is at minimum (Modbus300016 setting). and report pre-heat alarm.

- If $T_r < T_s - 1^\circ\text{C}$ (Modbus 300033 setting), then cool operation is terminated and MTV1 and AUX1 are turned off. Indoor fan runs at set speed. DA1 output is 0VDC.

When unit is turned off, MTV1 and AUX1 are off. DA1 is 0VDC. Fan is turned off after 30s.

The range of T_s is 16 - 30°C.

Indoor fan speed can be adjusted to low, medium, high and auto.

LOW TEMPERATURE PROTECTION OF INDOOR COIL IN COOLING MODE

If $T_{i1} \leq 2^\circ\text{C}$ for 2 minutes, MTV1 is turned OFF. DA1 is 0VDC. Indoor fan is set at Medium speed if fan runs at low speed.

If $T_{i1} \geq 5^\circ\text{C}$ for 2 minutes, MTV1 is turned ON. DA1 is set to original status. Indoor fan is changed to set speed.

FAN MODE

Indoor fan speed can be adjusted to low, medium and high. If fan speed is set to auto by Modbus, fan will run at low speed.

HEAT MODE

Without Electrical Heater (Modbus300043=0)

When unit is turned on in heating mode:

- When $T_r \leq T_s - 1^\circ\text{C}$ (Modbus 300033 setting), MTV1 and AUX2 are turned on. DA1 is at 10VDC for 2 minutes, check T_{i1} :

If $T_{i1} < 28^\circ\text{C}$ (Modbus 300017 setting), fan is turned on at low speed. DA1 is at 10VDC.

If $28^\circ\text{C} < T_{i1} < 28(\text{Modbus 3000017 setting}) + 4^\circ\text{C}$, fan is on at original state. DA1 is at original state.

If $T_{i1} \geq 28(\text{Modbus 3000017 setting}) + 4^\circ\text{C}$, fan is on at setting speed. DA1 output is based on water temperature difference (T_{i1}/T_{i2}) and Modbus parameter 300027 setting PID calculation. The output is minimum output (Modbus300015 setting) $\sim 10\text{VDC}$. If T_{i1} sensor is damaged, fan runs at setting speed.

- When $T_r > T_s + 1^\circ\text{C}$ (Modbus 300033 setting), MTV1 and AUX2 are turned off. DA1 is at 0VDC. fan will run at lowest speed.

When unit is turned off, MTV1 and AUX2 are turned off. DA1 is at 0VDC. Fan is turned off after 2 minutes.

With Electrical Heater as booster (Modbus300043=1)

When unit is turned on in heating mode:

- a) When $T_r \leq T_s - 1\text{ }^\circ\text{C}$ (Modbus 300033 setting), MTV1 and AUX2 are turned on. Fan is turned on at setting speed. DA1 is at 10VDC for 2 minutes, then check Ti1:

If $T_{i1} < 28\text{ }^\circ\text{C}$ (Modbus 300017 setting), EH is turned on. DA1 is at 10VDC.

If $28\text{ }^\circ\text{C} < T_{i1} < 28$ (Modbus 3000017 setting) $+4\text{ }^\circ\text{C}$, EH is kept at original state. DA1 is at original state.

If $T_{i1} \geq 28$ (Modbus 3000017 setting) $+4\text{ }^\circ\text{C}$, EH is turned off. DA1 output is based on water temperature difference (T_{i1}/T_{i2}) and Modbus parameter 300027 setting PID calculation. The output is minimum output (Modbus300015 setting) $\sim 10\text{VDC}$.

If Ti1 sensor is damaged, fan will run at set speed.

- b) When $T_r > T_s + 1\text{ }^\circ\text{C}$ (Modbus 300033 setting), MTV1 and AUX2 are turned off. EH is turned off. DA1 is at 0VDC. fan is turned on at low speed.

When unit is turned off, MTV1 and AUX2 are turned off. DA1 is at 0VDC. Fan is turned off after 2 minutes.

With Electrical Heater as primary heat source (Modbus300043=2)

When unit is turned on in heating mode: When $T_{i2} \leq 35\text{ }^\circ\text{C}$ (or T_{i2} is broken) and $T_r \leq T_s - 1\text{ }^\circ\text{C}$ (Modbus 300033 setting), Fan is turned on at setting speed, EH is turned on. When $T_r > T_s + 1\text{ }^\circ\text{C}$ (Modbus 300033 setting), EH is turned off. Fan is turned on at low speed.

When unit is turned off, EH is turned off. Fan is turned off after 2 minutes.

OVER-HEAT PROTECTION OF INDOOR COIL

If $T_{i1} \geq 75\text{ }^\circ\text{C}$, then MTV1, AUX2, DA1 and EH are turned off. Indoor fan remains on and runs at high speed.

If $T_{i1} < 70\text{ }^\circ\text{C}$, then unit keep original state.

If the indoor coil temperature sensor is damaged or not connected, the protection mode will be overridden and the unit will work according to the pre-heat and post-heat program.

DEHUMIDIFICATION MODE

When unit is turned on in dehumidification mode:

- a) AUX1 is turned on. T_s is $24\text{ }^\circ\text{C}$.
- b) If $T_r \geq 25\text{ }^\circ\text{C}$ for 30S, then MTV1 will be on for 3 minutes, and then off for 4 minutes. DA1 is on at 3 times of (Modbus 300016 setting). Fan is turned on at low speed.
- c) If $16\text{ }^\circ\text{C} \leq T_r < 25\text{ }^\circ\text{C}$ for 30S, then MTV1 will be on for 3 minutes, and then off for 6 minutes. DA1 is on at double of (Modbus 300016 setting). Fan is turned on at low speed.
- d) If $T_r < 16\text{ }^\circ\text{C}$ for 30S, then MTV1 will be on for 3 minutes, and then off for 10 minutes. DA1 is on at (Modbus 300016 setting). Fan is turned on at low speed.
- e) At the end of the above dehumidification cycle, the system will decide the next dehumidification control option.

AUTO MODE

When unit is turned on in Auto mode, fan is turned on at setting speed for 30s, then check T_r and T_s :

If $T_s \geq T_r + 3\text{ }^\circ\text{C}$, the unit runs in heating mode. If $T_r - 3\text{ }^\circ\text{C} < T_s < T_r + 3\text{ }^\circ\text{C}$, the unit runs in fan mode. If $T_s < T_r - 3\text{ }^\circ\text{C}$, the unit runs in cooling mode. If unit working mode is confirmed, the unit will not change the working mode. After the unit is turned off and restart in 2 hours, working mode will be confirmed again.

PRO INPUT FUNCTION

Standard Setting when the unit is on:

If PRO input is closed for 60S, the unit is turned off.

If PRO input is opened for 60S, the unit is turned on.

Other function can be set in Modbus.

2-pipe Control Logic – without Valve**COOL MODE**

When unit is turned on in cooling mode: If $T_r \geq T_s + 1^\circ\text{C}$ (Modbus 300033 setting), AUX1 is closed. Fan is turned on at setting speed. If $T_r < T_s$, then cool operation is terminated and AUX1 is turned off. Indoor fan runs at super low speed.

When unit is turned off, AUX1 is off. Fan is turned off after 30s.

The range of T_s is 16 - 30°C.

Indoor fan speed can be adjusted to low, medium, high and auto.

LOW TEMPERATURE PROTECTION OF INDOOR COIL IN COOLING MODE

If $T_{i1} \leq 2^\circ\text{C}$ for 2 minutes, indoor fan is set at Medium speed if fan runs at low speed.

If $T_{i1} \geq 5^\circ\text{C}$ for 2 minutes, indoor fan is changed to set speed.

FAN MODE

Indoor fan speed can be adjusted for low, medium and high. If fan speed is set at auto by Modbus, fan will run at low speed.

HEAT MODE**Without Electrical Heater (Modbus300043=0)**

When unit is turned on in heating mode:

a) When $T_r \leq T_s - 1^\circ\text{C}$ (Modbus 300033 setting), AUX2 is turned on and check T_{i1} in 2 minutes:

If $T_{i1} < 28^\circ\text{C}$ (Modbus 300017 setting), fan is turned on at low speed.

If $28^\circ\text{C} < T_{i1} < 28(\text{Modbus 3000017 setting}) + 4^\circ\text{C}$, fan is on at original state.

If $T_{i1} \geq 28(\text{Modbus 3000017 setting}) + 4^\circ\text{C}$, fan is on at setting speed.

If T_{i1} sensor is damaged, fan works at setting speed.

b) When $T_r > T_s + 1^\circ\text{C}$ (Modbus 300033 setting), AUX2 is turned off. Fan runs at lowest speed.

When unit is turned off, AUX2 is turned off. Fan works at setting speed. If $T_{i1} \geq 38^\circ\text{C}$, fan is turned off after 2 minutes.

With Electrical Heater as booster (Modbus300043=1)

When unit is turned on in heating mode:

a) When $T_r \leq T_s - 1^\circ\text{C}$ (Modbus 300033 setting), AUX2 is turned on. Fan is turned on at setting speed, then check T_{i1} in 2 minutes:

If $T_{i1} < 28^\circ\text{C}$ (Modbus 300017 setting), EH is turned on.

If $28^\circ\text{C} < T_{i1} < 28(\text{Modbus 3000017 setting}) + 4^\circ\text{C}$, EH is kept at original state.

If $T_{i1} \geq 28(\text{Modbus 3000017 setting}) + 4^\circ\text{C}$, EH is turned off.

If T_{i1} sensor is damaged, fan will run at set speed.

b) When $T_r > T_s + 1^\circ\text{C}$ (Modbus 300033 setting), AUX2 is turned off. EH is turned off. Fan is turned on at low speed.

When unit is turned off, AUX2 is turned off. Fan is turned off after 2 minutes.

With Electrical Heater as primary heat source (Not available)**OVER-HEAT PROTECTION OF INDOOR COIL**

If $T_{i1} \geq 75^\circ\text{C}$, then AUX2 is turned off. Indoor fan remains on and runs at high speed.

If $T_{i1} < 70^\circ\text{C}$, then unit keep original state.

If the indoor coil temperature sensor is damaged or not connected, the protection mode will be overridden and the unit will work according to the pre-heat and post-heat program.

DEHUMIDIFICATION MODE

When dehumidification mode is on, AUX1 is turned on and fan is turned on at low speed.

AUTO MODE (Not available)

2-pipe Control Logic -With 6-way Modulating Valve

COOL MODE

When unit is turned on in cooling mode:

- a) If $T_r \geq T_s + 1^\circ\text{C}$ (Modbus 300033 setting), MTV1 is turned on. AUX1 is closed. Fan is turned on at setting speed. DA1 is turned on at 0VDC for 2 minutes, then check Ti1:

When $T_{i1} \leq 8^\circ\text{C}$, DA1 output is based on water temperature difference (T_{i1}/T_{i2}) and Modbus parameter 300027 setting PID calculation. The output is 4~0VDC.

When $8 < T_{i1} \leq 10^\circ\text{C}$, DA1 output is based on water temperature difference (T_{i1}/T_{i2}) and Modbus parameter 300027 setting minus 1 PID calculation. The output is 4~0VDC.

When $10 < T_{i1} \leq 12^\circ\text{C}$, DA1 output is based on water temperature difference (T_{i1}/T_{i2}) and Modbus parameter 300027 setting minus 2 PID calculation. The output is 4~0VDC.

When $12 < T_{i1} \leq 15^\circ\text{C}$, DA1 output is based on water temperature difference (T_{i1}/T_{i2}) and Modbus parameter 300027 setting minus 3 PID calculation. The output is 4~0VDC.

When $15 < T_{i1} \leq 28^\circ\text{C}$ (Modbus 300017 setting), DA1 output is kept at 0VDC.

When $T_{i1} > 28^\circ\text{C}$ (Modbus 300017 setting), DA1 output is 4VDC. and report pre-heat alarm.

- b) If $T_r < T_s - 1^\circ\text{C}$ (Modbus 300033 setting), then cool operation is terminated and MTV1 and AUX1 are turned off. Indoor fan runs at set speed. DA1 output is 5VDC.

When unit is turned off, MTV1 and AUX1 are off. DA1 is 5VDC. Fan is turned off after 30s.

The range of T_s is 16 - 30°C

Indoor fan speed can be adjusted to low, medium, high and auto.

LOW TEMPERATURE PROTECTION OF INDOOR COIL IN COOLING MODE

If $T_{i1} \leq 2^\circ\text{C}$ for 2 minutes, MTV1 is turned OFF. DA1 is set to 5Vdc. Indoor fan is turned on at Medium speed if fan runs at low speed. If $T_{i1} \geq 5^\circ\text{C}$ for 2 minutes, MTV1 is turned ON. DA1 is set to original status. Indoor fan is changed to set speed.

FAN MODE

Indoor fan speed can be adjusted for low, medium and high. If fan speed is set auto by Modbus, fan runs at low speed.

HEAT MODE

Without Electrical Heater (Modbus300043=0)

When unit is turned on in heating mode:

- a) When $T_r \leq T_s - 1^\circ\text{C}$ (Modbus 300033 setting), MTV2 and AUX2 are turned on. DA1 is at 10VDC for 2 minutes, then check Ti1:

If $T_{i1} < 28^\circ\text{C}$ (Modbus 300017 setting), fan is turned on at low speed. DA1 is at 10VDC.

If $28^\circ\text{C} < T_{i1} < 28(\text{Modbus 3000017 setting}) + 4^\circ\text{C}$, fan is on at original state. DA1 is at original state.

If $T_{i1} \geq 28(\text{Modbus 3000017 setting}) + 4^\circ\text{C}$, fan is on at setting speed. DA1 output is based on water temperature difference (T_{i1}/T_{i2}) and Modbus parameter 300027 setting PID calculation. The output is 6~10VDC.

If Ti1 sensor is damaged, fan is worked at setting speed.

- b) When $T_r > T_s - 1^\circ\text{C}$ (Modbus 300033 setting), MTV1 and AUX2 are turned off. DA1 is at 5VDC. fan is turned on at lowest speed.

When unit is turned off, MTV1 and AUX2 are turned off. DA1 is at 5VDC. Fan is turned off after 2 minutes.

With Electrical Heater as booster (Modbus300043=1)

When unit is turned on in heating mode:

- a) When $T_r \leq T_s - 1^\circ\text{C}$ (Modbus 300033 setting), MTV2 and AUX2 are turned on. Fan is turned on at setting speed. DA1 is at 10VDC for 2 minutes, then check Ti1:

If $T_{i1} < 28^\circ\text{C}$ (Modbus 300017 setting), EH is turned on. DA1 is at 10VDC.

If $28^\circ\text{C} < T_{i1} < 28(\text{Modbus 3000017 setting}) + 4^\circ\text{C}$, EH is kept at original state. DA1 is at original state.

If $T_{i1} \geq 28(\text{Modbus 3000017 setting}) + 4^\circ\text{C}$, EH is turned off. DA1 output is based on water temperature difference (T_{i1}/T_{i2}) and Modbus parameter 300027 setting PID calculation. The output is 6~10VDC.

If Ti1 sensor is damaged, fan is worked at setting speed.

- b) When $T_r > T_s - 1^\circ\text{C}$ (Modbus 300033 setting), MTV2 and AUX2 are turned off. EH is turned off. DA1 is at 5VDC. fan is turned on at low speed.

When unit is turned off, MTV2 and AUX2 are turned off. DA1 is at 5VDC. Fan is turned off after 2 minutes.

OVER-HEAT PROTECTION OF INDOOR COIL

If $T_{i1} \geq 75^\circ\text{C}$, then MTV1, AUX2, DA1 and EH are turned off. Indoor fan remains on and runs at high speed.

If $T_{i1} < 70^\circ\text{C}$, then unit keep original state.

If the indoor coil temperature sensor is damaged or not connected, then the protection mode will be overridden and the unit will work according to the pre-heat and post-heat program.

DEHUMIDIFICATION MODE**When unit is turned on in dehumidification mode:**

AUX1 is turned on. Ts is 24 °C. If Tr ≥ 25°C for 30S, then MTV1 will be ON for 3 minutes, then OFF for 4 minutes. DA1 is 2VDC. Fan is turned on at low speed. If 16°C ≤ Tr < 25°C for 30S, then MTV1 will be ON for 3 minutes, and then OFF for 6 minutes. DA1 is 2.5VDC. Fan is turned on at low speed. If Tr < 16°C for 30S, then MTV1 will be ON for 3 minutes, and then OFF for 10 minutes. DA1 is 3.5VDC. At the end of dehumidification cycle, the system will decide the next dehumidification cycle.

AUTO MODE

When unit is turned on in Auto mode, fan is turned on at setting speed for 30S, then check Tr and Ts.

If Ts ≥ Tr + 3 °C, the unit is worked in heating mode. If Tr - 3 °C < Ts < Tr + 3 °C, the unit is worked in fan mode. If Ts < Tr - 3 °C, the unit is worked in cooling mode.

If unit works in heating or fan mode, when Tr - Ts > 3.0°C, MTV2, MTV1 and DA1 are off for more than 10minutes. EH is off for more than 10 minutes, the unit will work in cooling mode. If unit works in cooling or fan mode, when Ts - Tr > 3.0°C, MTV2, MTV1 and DA1 are off for more than 10minutes. the unit will work in heating mode.

PRO INPUT FUNCTION

Standard Setting when the unit is on:

If PRO input is closed for 60S, the unit is turned off.

If PRO input is opened for 60S, the unit is turned on.

Other function can be set in Modbus.

B.3. Sleep Mode

- a) The sleep mode can only be set when the unit is in cool mode or heat mode.
- b) If the sleep mode is activated in cool mode, the indoor fan runs at auto speed and Ts will increase by 0.5°C for every 30 minutes. The Maximum increasing temperature is 3°C. If the sleep mode is activated in heat mode, the indoor fan runs at auto speed and Ts will decrease by 0.5°C for every 30 minutes.
- c) If sleep mode is turned off, setting temperature goes back and fan is changed to set speed.

B.4. Auto Fan Speed

Cooling Mode: Fan speed cannot change until it has run for more than 30 seconds.

Heat Mode: Fan speed cannot change until it has run for more than 30 seconds.

B.5. Stepping MotorFor remote handset

Whenever the indoor fan is running, the louver can swing or stop at the desired position.

Louver angle: 0~100°, opens clockwise with widest angle at 100°.

Swing angle: 35~100°, opens clockwise to 68°. Below are the 4 fixed positions which can be set from wireless handset.

Position	Angle
1	35°
2	57°
3	83°
4	100°

For wired wall pad

Louver angle: 0~100°, opens clockwise, with widest angle at 100°.

Swing angle: 35~100°, opens clockwise to 68°. User may stop louver at any desired position between 35~100°.

B.6. Buzzer

The unit will beep once when it receives 1 signal.

B.7. Auto Restart

The system uses non-volatile memory to save the present operation parameters when system is turned off or in case of system failure or cessation of power supply. Operation parameters are mode, set temperature, louver's position, and the fan speed. When power supply resumes or the system is switched on again, the same operations as previously set will function.

B.8. On/Off Switch

- a) This is a TACT switch to select Cool→Heat→Off operation mode.
- b) In COOL mode, the set temperature of the system is 24°C with auto fan speed. There are no timer and sleep modes.
- c) In HEAT mode, the set temperature of the system is 24°C with auto fan speed. There are no timer and sleep modes.
- d) Master unit that does not use a wall pad will globally broadcast.

Note: When button pressing is effective, the master unit buzzer will beep twice and the slave unit will beep once.

B.9. Electric Heater Safety Switch

- Before the electrical heater is turned on, the EH safety switch must be closed and EH is opened for 3 minutes and EC motor RPM must be more than Modbus 300020 setting.
- When electrical heater is ON, electrical heater safety switch is opened for ≥ 1 second or EC motor RPM is lower than Modbus 300020 setting, EH will be turned off immediately and report an error and fan speed is changed to high speed.
- Once the contact is returned to the closed ≥ 180 seconds and EC motor RPM is more than 300020 setting, reset the error and the heater will start again.
- When the EH safety switch is opened ≥ 3 times within 60 minutes the heater is not allowed to start anymore.
- Turn off the unit to reset the fault, provided that the switch has returned to the closed position.

B.10. Low Temperature Protection of Indoor Coil in Winter

This is frost protection when the unit is off to prevent water from freezing in the coil.

If a 2-pipe system is in Standby Mode, when $T_r \leq 2$ °C for 2 minutes, MTV1 is turned on. AUX2 is on. DA1 is 5VDC. If $T_{i1} < 5$ °C for 2 minutes, EH (if present) is switched on. Indoor fan is turned on at low speed. If $T_r \geq 5$ °C for 2 minutes, MTV2 is turned off. AUX2 is off. DA1 is 0VDC. Electric Heater is turned off. Indoor fan is switched off.

If a 4-pipe system (or 2-pipe unit with 6-way valve) is in Standby Mode, when $T_r \leq 2$ °C for 2 minutes, MTV2 is turned on. AUX2 is on. DA2 is 5VDC. (DA1 is 8VDC if using 6-way valve) If $T_{i1} < 5$ °C for 2 minutes EH (if present) is switched on. Indoor fan is turned on at low speed. If $T_r \geq 5$ °C for 2 minutes, MTV2 is turned off. AUX2 is off. DA2 is 0VDC. (DA1 is 5VDC if using 6-way valve) Electric Heater is turned off. Indoor fan is switched off.

B.11. Open Modbus Protocol

Transfer Mode: RTU BAUD Rate:9600bps, 8 data bits, 1 stop bit, None parity bit

The communications require a delay between reading an answer and sending the next command of 80 ms. All temperature is equal to reading data*10 accuracy: 0.1 degree C.

Supported Functions

Function Code	Function description
01(01H)	Read Coils
02(02H)	Read Discrete Inputs
03(03H)	Read Holding Registers
04(04H)	Read Input Registers
05(05H)	Write Single Coil
06(06H)	Write Single Register
15(0FH)	Write Multiple Coils
16(10H)	Write Multiple Registers
255(FFH)	Extended Commands which is used to test.

Valid Error code table:

Error code	description	definition
01 (01H)	Invalid commands	Received commands beyond valid commands
02 (02H)	Invalid data address	Data addresses beyond valid data address
03 (03H)	Invalid data	Data beyond definition range
04 (04H)	Write data not succeed	Write data not succeed

Coils table:

Description	Address	Type*	Remark
ON/OFF	100000	R/W	
Sleeping mode	100001	R/W	
Louver swings	100002	R/W	
Energy Saving Mode	100003	R/W	
PRO function	100004	R/W	

Discrete table:

Description	Address	Type*	Remark
MTV1	200000	R	
MTV2	200001	R	
AUX1	200002	R	
AUX2	200003	R	
Condensate pump	200004	R	
Electrical heater	200005	R	
Wired wall pad	200006	R	
PR-O1	200007	R	
Float switch	200008	R	
Reserved	200009	R	
EH safety switch	200010	R	
Internal test	200011	R	Testing purpose only.

Holding Register table:

Description	Address	Type*	Remark
Mode setting	300000	R/W	Cooling mode = 01(H), Humidify mode = 02(H), Fan mode = 04(H), Heating mode = 08(H), Auto mode = 10(H)
Fan speed setting	300001	R/W	Low speed = 04(H), Medium speed = 02(H), High speed = 01(H) Auto fan speed = 07(H)
Louver swing setting	300002	R/W	Position1=01(H), Position2=02(H), Position3=03(H), Position4=04(H), Auto=0F(H), Stop=00(H)
Setting temperature	300003	R/W	16~30 (actual*10 format)
Address setting	300004	R/W	1~255
Reset	300005	W	=0x33 reset error
Reserved	300006	W	
Reserved	300007	W	
Reserved	300008	W	
Reserved	300009	W	
Hours in Timer on	300010	R/W	Timer ON
Minute in Timer on	300011	R/W	Timer ON
Hours in Timer off	300012	R/W	Timer OFF
Minute in Timer off	300013	R/W	Timer OFF
Icon of Timer ON or OFF	300014	R/W	BIT0 = Icon of Timer ON, BIT1 = Icon of Timer OFF, 1 = enable, 0 = disable
Minimum output DA1	300015	R/W	Default 25% (2.5vdc)
Minimum output DA2	300016	R/W	Default 25% (2.5vdc)
Pre-heat temperature setting	300017	R/W	25~35, default: 30

Reserved	300018	R/W	Default: 40% (4VDC) or (10.4mA)
Super low speed rpm	300019	R/W	0~10V, default:2VDC
Low speed rpm	300020	R/W	1~10VDC, default: 3VDC
Medium speed rpm	300021	R/W	1~10VDC, default: 6VDC
High speed rpm	300022	R/W	1~10VDC, default: 8.5VDC
Signal output setting	300023	R/W	1~10VDC (used to test,0 = disable)
Temperature sampling time	300024	R/W	2~100, default: 55
Factor of auto fan speed	300025	R/W	2~150, default:20
Factor of modulating valve	300026	R/W	2~250, default:150
Ti1 and Ti2 difference setting	300027	R/W	3~15, default:5
Reserved	300028	R/W	3~15, default:10
Controller Hardware type setting	300029	R/W	0=air cleaner (S5) 1=FCU (S1/S2/S3, SWC-S) (Default) 2=AHU (S6) or (AHU+W5) 3=AHU+AQI (S5+S6) 4=Zone controller(S7)
Degree unit setting	300030	R/W	0=degree C 1=degree F
Temperature display setting	300031	R/W	0=Room temperature display on LED 1=Setting temperature display on LED
Setting temperature range	300032	R/W	0=setting temperature range is from 16~30 1=Setting temperature range is fixed. Cooling=24oC Heating=21oC
Temperature band setting	300033	R/W	1~9, default:1
Reserved	300034	R/W	30~200, default:60
Reserved	300035	R/W	10~80, default:50
Reserved	300036	R/W	460~1200, default:800
Reserved	300037	R/W	100~500, default:200
Reserved	300038	R/W	30~70, default:50
Reserved	300039	R/W	10~30, default:10
Reserved	300040	R/W	100~1000, default:500
Reserved	300041	R/W	500~9000, default: 2000
Reserved	300042	R/W	500~9000, default: 2000
Reserved	300043	W	1
Reserved	300044	W	1
Reserved	300045	W	1
Software type	300046	R/W	0=2-pipe+MTV 1=2-pipe without valve 2=4-pipe+std valve 3=4-pipe+6-way valve
EH type	300047	R/W	0=without EH, 1=EH as booster; 2=EH as primary
DA1 control signal	300048	R/W	0=Tr/Ts, 1=ESP
EC motor input ports	3000049	R/W	0=CN4 working (Default) 1=CN5 working 2=CN4+CN5 working
PRO1 input type	300050	R/W	0=N, 1=NC
Tr sensor setting	300051	R/W	0=sensor on the wired wall pad (Default) 1=sensor on the main PCB
Reserved	300052	R/W	0~120, default: 80
Optimized swing angle	300053	R/W	200~999 default:0;
E-heater	300054	R/W	Unit: KW*10
Room temp. factor	300055	R/W	90~120, default:103
Water inlet temp. factor	300056	R/W	90~120, default:103
Delta T factor	300057	R/W	90~120, default:102
Product type	300058	R/W	00~99; default:00
Product model	300059	R/W	000~999; default:000
Ex-works data	300060	R/W	0000~9999
Software version	300061	R	10~99 default:10
Hardware version	300062	R	10~99 default:10
Reserved	300063	R/W	200rpm~1500rpm default:500
Reserved	300064	R/W	200rpm~1500rpm default:1200
Reserved	300065	R/W	200rpm~1500rpm default:500
Reserved	300066	R/W	200rpm~1500rpm default:1200
Reserved	300067	R/W	0=EC motor1 working 1=EC motor2 working 2=EC motor 1/2 working default:2
In auto mode, temp. Band setting	300068	R/W	1~15, default: 3
Reserved	300069	R/W	
Reserved	300070	R/W	
Unit power input at High speed	300071	R/W	W*10
Unit power input at Med. speed	300072	R/W	W*10
Unit power input at Low speed	300073	R/W	W*10
Unit heat capacity at High speed	300074	R/W	KW*10
Unit heat capacity at Med. speed	300075	R/W	KW*10

Unit heat capacity at Low speed	300076	R/W	KW*10
Unit cool capacity at High speed	300077	R/W	KW*10
Unit cool capacity at Med. speed	300078	R/W	KW*10
Unit cool capacity at Low speed	300079	R/W	KW*10

Input Register table:

Description	Address	Type*	Remark
Tr temperature sensor	400000	R	
Ti1 temperature sensor	400001	R	
Ti2 temperature sensor	400002	R	
Reserved	400003	R	
Reserved	400004	R	
Error code	400005	R	Bit0 = Room temperature sensor error Bit1 = Ti1 temperature sensor error Bit2 = Ti2 temperature sensor error Bit3 = Float switch error Bit4 = Indoor coil low temperature protection Bit5 = Indoor coil over heat protection Bit6 = Filter switch Bit7 = Electrical heater failure Bit8 = Motor1 Error Bit9 = Motor2 Error Bit10 = System parameters error Bit11 = Anti-frozen error Bit12 = Ti3 temperature sensor error Bit13 = Ti4 temperature sensor error Bit14 = PM2.5 sensor Bit15 = AQI Error
Fan speed status	400006	R	Low = 04(H) Medium = 02(H) High = 01(H)
Reserved	400007	R	
Reserved	400008	R	
EH	400009	R	0= disable, 1=booster, 2=primary
Unit type	400010	R	
DA1	400011	R	
DA2	400012	R	
Reserved	400013	R	
Reserved	400014	R	
Reserved	400015	R	
Reserved	400016	R	
Unit status	400017	R	Cooling mode = 01(H) Humidify mode = 02(H) Fan mode = 04(H) Heating mode = 08(H) Unit OFF=32(H)
Temperature in wall pad	400018	R	
Motor running time	400019	R	
Motor running terms	400020	R	0~100,
Cooling capacity	400021	R	
Cooling capacity terms	400022	R	0~100,
Heating capacity	400023	R	
Heat capacity terms	400024	R	0~100,
Reserved	400025	R	
Reserved	400026	R	
EC motor1 actual RPM	400036	R	
EC motor2 actual RPM	400037	R	
EC motor1 error	400038	R	
EC motor2 error	400039	R	

* R = read only, W = write only, R/W = read and write.

B.12. LED Display and Error Descriptions

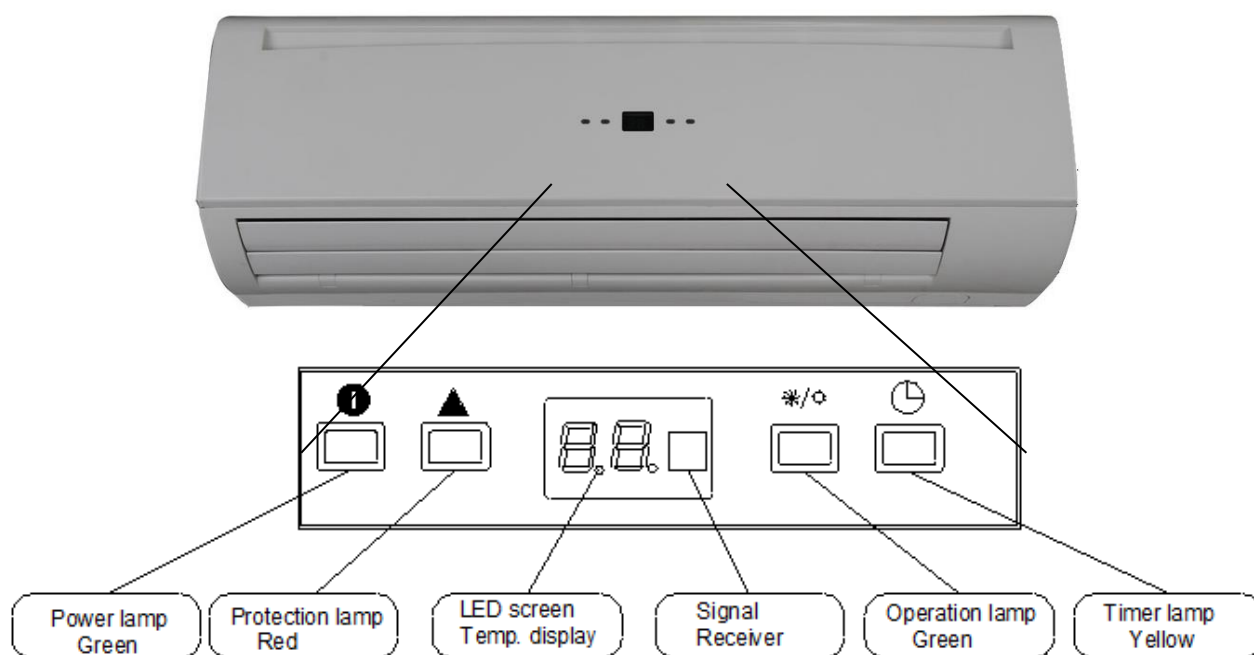

Power / Operation LED light (both green)	
Unit on	Power LED Off, Operation LED On
Unit in standby	Power LED On, Operation LED Off

Error Description	For all units - Green LED			
	Blink	LED display	Reason	Remedy
Return air sensor failure	Green LED blinks 1 times, stops for 3s	E1	Room sensor unplugged or damaged.	1. Check if Tr plug is connected or not. 2. Check if sensor's resistance is correct or not.
Indoor coil sensor 1 failure	Green LED blinks 2 times, stops for 3s	E2	Ti1 sensor unplugged or damaged.	1. Check if Ti1 plug is connected or not. 2. Check if sensor's resistance is correct or not.
Indoor coil sensor 2 failure	Green LED blinks 3 times, stops for 3s	E3	Ti2 sensor unplugged or damaged.	1. Check if Ti2 plug is connected or not. 2. Check if sensor's resistance is correct or not.
Water pump failure	Green LED blinks 4 times, stops for 3s	E4	Float switch is opened.	1. Check if the condensate water pipe is connected or not. 2. Check if the pump is functioning or not.
Indoor coil low temperature protection	Green LED blinks 5 times, stops for 3s	E5	Water temperature is lower than 3 °C.	Check the water temperature.
Indoor coil over heat protection	Green LED blinks 6 times, stops for 3s	E6	Water temperature is higher than 70 °C.	Check the water temperature
Filter Switch (S6 PCB)	Green LED blinks 7 times, stops for 3s	E7	Filter switch is opened.	1. Check if filter block or not 2. replace teh new filter
Electric Heater failure	Green LED blinks 8 times, stops for 3s	E8	Only for unit with EH.	1. Change fan speed to high.

			EH safety switch is opened.	2. Replace the damaged EH safety switch.
EC motor failure(CN4)	Green LED blinks 9 times, stops 3s	E9	No EC motor feedback	1. Check Modbus setting. 2. Check the EC motor.
EC motor failure(CN5)	Green LED blinks 10 times, stops 3s	E10	No EC motor feedback	1. Check Modbus setting. 2. Check the EC motor.
Anti-frozen protection	Green LED blinks 12 times, stops for 3s	E12	When unit is standby, $Tr < 2^{\circ}\text{C}$.	1. Turn on unit to keep Tr high than 5°C
Indoor coil sensor 3 failure (S6 PCB)	Green LED blinks 13 times, stops for 3s	E13	Ti3 sensor unplugged or damaged.	1. Check if Ti3 plug is connected or not. 2. Check if sensor's resistance is correct or not.
Indoor coil sensor 4 failure (S6 PCB)	Green LED blinks 14 times, stops for 3s	E14	Ti4 sensor unplugged or damaged.	1. Check if Ti4 plug is connected or not. 2. Check if sensor's resistance is correct or not.
PM2.5 sensor failure (S6 PCB)	Green LED blinks 15 times, stops for 3s	E15	PM2.5 sensor unplugged or damaged.	1. Check if PM2.5 plug is connected or not. 2. Check if sensor's resistance is correct or not.
AQI sensor failure (S6 PCB)	Green LED blinks 16 times, stops for 3s	E16	AQI sensor unplugged or damaged.	1. Check if AQI plug is connected or not. 2. Check if sensor's resistance is correct or not.

C. Master Slave Network Setup

1. Disconnect the communication plug from the control box. Connect A to A and B to B for every unit.



2. If the total length of wire is more than 1000m, please use shielded wire in order to protect the signal transmission.



3. First unit at left, middle units in the middle and last unit at right. Check wire contacts by a multi-meter after connections.

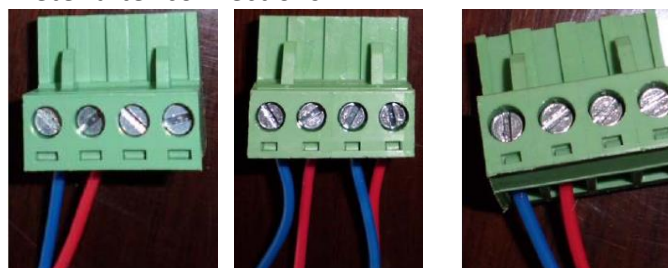

First unit

Middle units

Last unit

4. Check 1 and 2, 3 and 4, 5 and 6 to be sure the connections are correct. If the resistance between two wire contacts is too high, reconnect the wire contacts. Reconnect the communication plug to the control box.

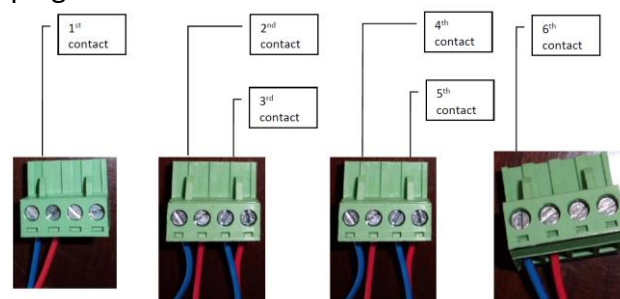

D. User Interface

D.1. Remote Handset

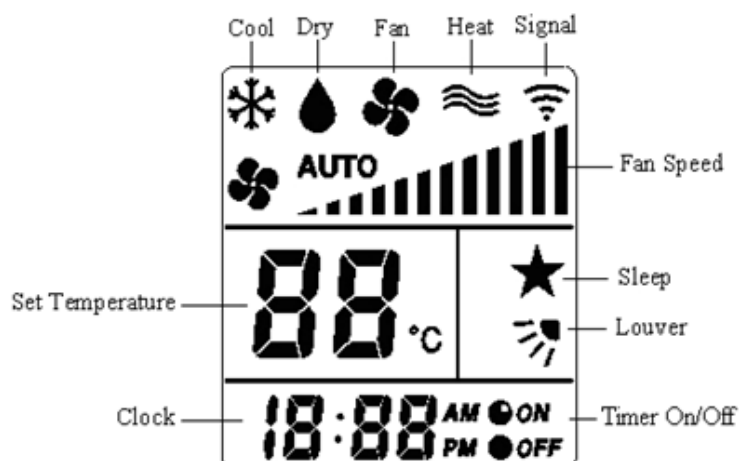
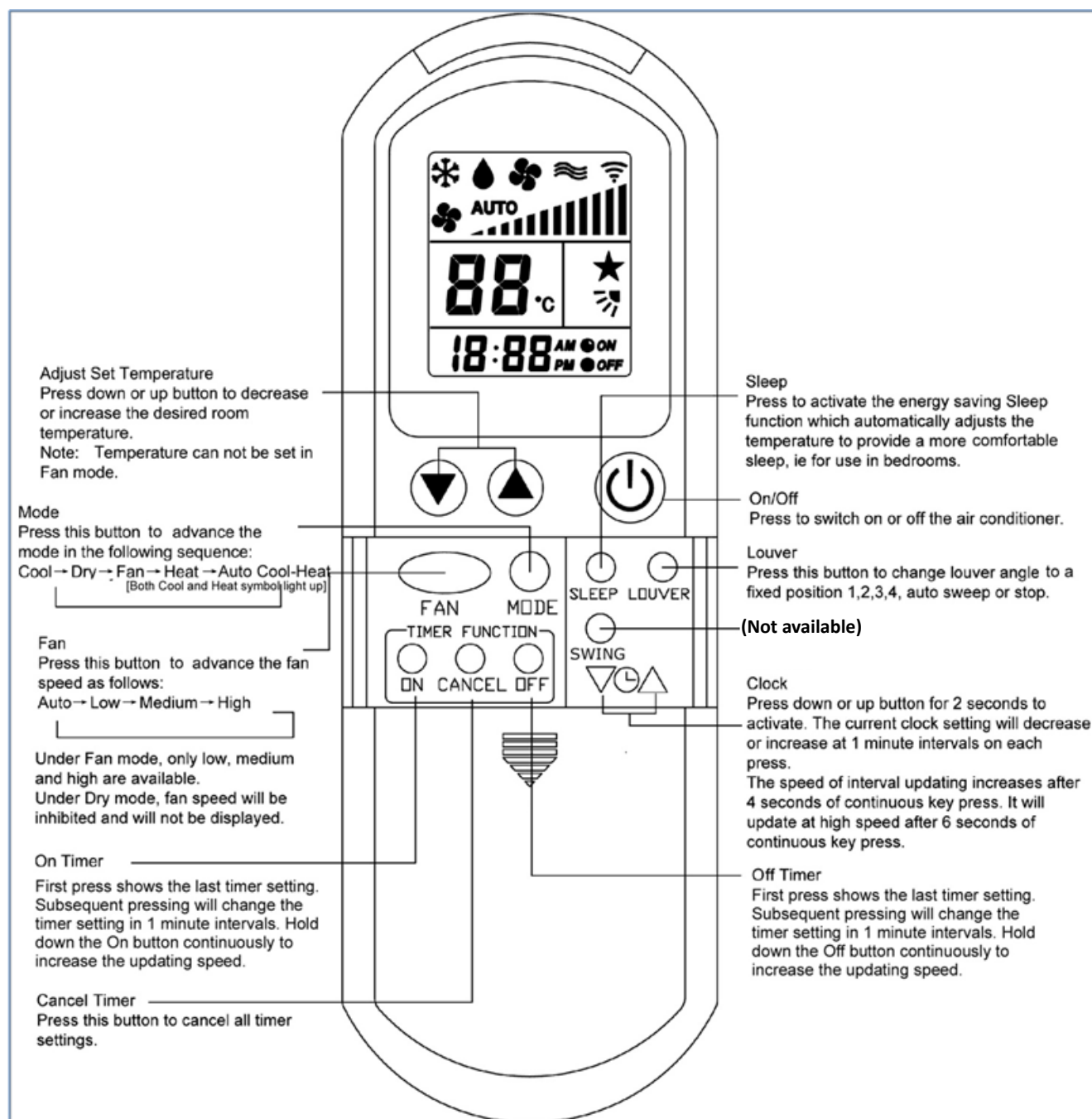

Attention

When unit with handset is the master unit, its settings are automatically sent to the slave units.

Auto Cool-Heat operation will be applicable in 4-pipe system only.

“Louver” function is available.

“Swing” function is not applicable.

European version only uses degree C setting.

D.2. Wall Pad

Display

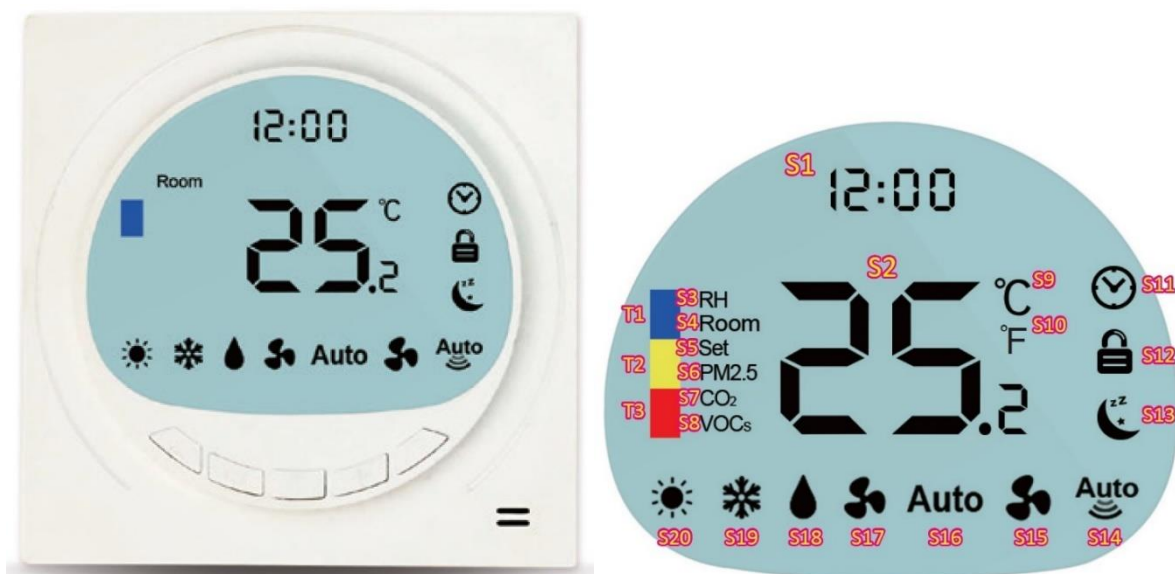

S1: Real Time	S11: Timer ON/OFF	T1: Blue color: Excellent Air Quality
S2: Temp Display	S12: Keypad Lock	T2: Yellow color: Good Air Quality
S3: RH	S13: Sleep Mode	T3: Red color: Poor Air Quality
S4: Room Temp	S14: H/M/L/Auto Speed	
S5: Set Temp	S15: Fan	
S6: PM2.5 (ug/m3)	S16: Auto mode	
S7: CO2 (ppm)	S17: Fan mode	
S8: VOCs (PPb)	S18: Dehumidification mode	
S9: Degree C	S19: Cooling mode	
S10: Degree F	S20: Heating mode	

User Operation

Button					
Name	On/Off	Mode	Up	Down	Fan
Function	Switch on or off the unit	Switch between modes	Modify parameters	Modify parameters	Change Fan Speed



Lock Screen: Press and at the same time for 5 seconds until displayed to lock the screen. Press and for 5 seconds again until disappeared to unlock the screen.

Boot by Timer: When power is off, press for 5 seconds to enter Boot by Timer interface. Range is from 0 to 720 minutes. Time is increased by 30 minutes for every press.

Off by Time: When power is on, press for 5 seconds to enter Off by Timer interface. Range is from 30 to 720 minutes. Time is increased by 30 minutes for every press.

Sleep Mode: When power is on, press for 5 seconds until displayed.

Parameters Settings

When the wall pad is off, press and hold  and  for 5 seconds to enter Parameter Setting Mode. Press  to select parameters from 1 to 20.

Parameter 1: Unit Type,

0=Air Cleaner, only Fan mode available. It displays Temperature, RH, CO2, PM2.5, VOCs.

1=FCU, Cooling, Heating, Fan, Dehumidification and Auto modes available. Only displays Temperature.

2=AHU, Cooling, Heating, Fan, Dehumidification and Auto modes available. Only displays Temperature.

3=AHU + Air Cleaner, Cooling, Heating, Fan, Dehumidification and Auto modes available. It displays Temperature, RH, CO2, PM2.5, VOCs.

Parameter 2: Temperature Display, 0 = Celsius, 1 = Fahrenheit.

Parameter 3: Sensor Display, 0 = Room temperature value, 1 = Set temperature value.

Parameter 4: Temperature Range Setting, 0 = Range from 16~30 °C, 1 = Fixed at 24 °C when Cooling and 21 °C when Heating.

Parameter 5: Temperature Band, from 1 to 9, default: 1.

Parameter 6: PM2.5 Setting: 30~200, default: 60

Parameter 7: PM2.5 band setting: 10~80, default: 50

Parameter 8: CO2 setting: 460~1200, default: 800

Parameter 9: CO2 band setting: 100~500, default: 200

Parameter 10: Reserved

Parameter 11: Reserved

Parameter 12: RH setting: 30~70, default: 50

Parameter 13: RH band setting: 10~30, default: 10

Parameter 14: Unit address setting: 0~31, default: 0

Parameter 15: ESP setting: 0~100%, default: 40% when Parameter 1 setting is 2 or 3

Parameter 16: Reserved

Parameter 17: Unit configuration setting, 0=2-pipe with valve, 1=2-pipe without valve, 2=4-pipe with std valve, 3=4-pipe with 6-way valve

Parameter 18: Reserved

Parameter 19: DA1 function-When Parameter 1=2 or 3, Parameter 19=0: Fan control signal is based on Tr, Ts PID calculation. Parameter 19=1: Fan control signal is based on ESP PID calculation

Parameter 20: Offset of sensor in wired wall pad: -5~5, default: -3

Parameter 21: EH type, 0=without EH, 1=EH as booster, 2=EH as primary

Parameter 22: Room temperature setting, 0=room sensor in wired wall pad; 1=room sensor in main PCB

Dimensions and Installation

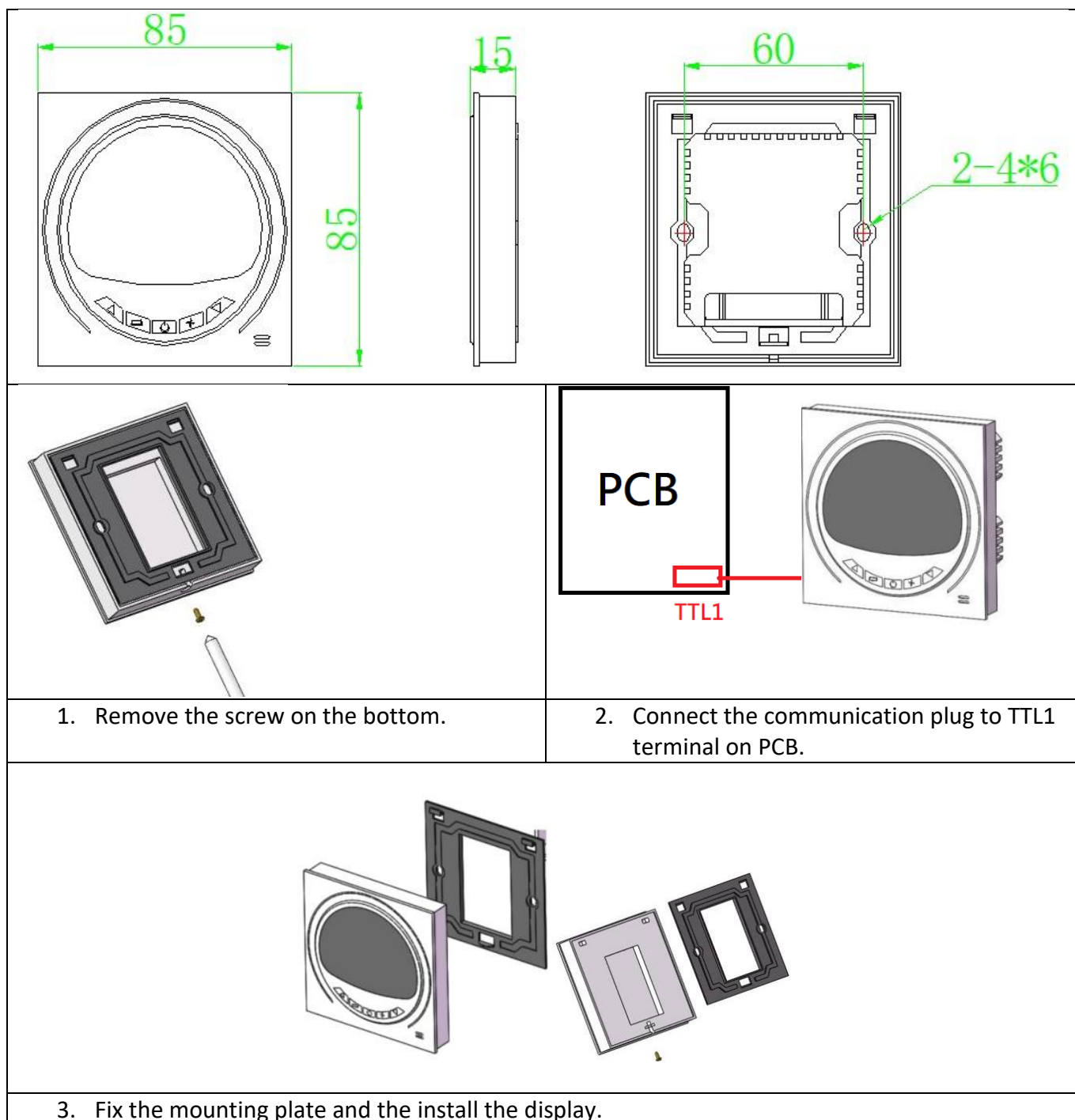

E. Maintenance

E.1. Opening and Closing of Lift-Up Grille Cover



Open the grille cover by lifting from the bottom position indicated by the arrows.



Close the grille cover by pressing down at the positions indicated by the arrows.

E.2. Front Cover Assembly Removal

1. Set the horizontal louver to the horizontal position.
2. Remove the screw caps below the louver, and then remove the mounting screws.
3. Open the lift-up grille cover by grasping the panel at both sides as shown above.
4. Remove the remaining screws located in the center of the front cover.
5. Grasp the lower part of the front cover and pull the entire assembly out and up towards you.

E.3. Air Vent and Water Purge Valves

1. After connecting the water inlet and outlet pipes to the main supply lines turn on the main breaker and operate the unit in COOLING mode.
2. Open the water inlet valve and flood the coil.
3. Check all connections for water leakage. If no leak is found, open the purging valve with an open end wrench while supporting the unit with your other hand. Then purge the air trapped inside the coil. When performing this activity, take care not to touch the electrical parts.
4. Close the purging valve when no bubbles appear.
5. Open the water outlet valve.

E.4. Wiring Connections

Unit components are wired to the terminal block of the indoor unit. Wiring can be accessed from the terminal block inside the control box.

F. Troubleshooting Guide

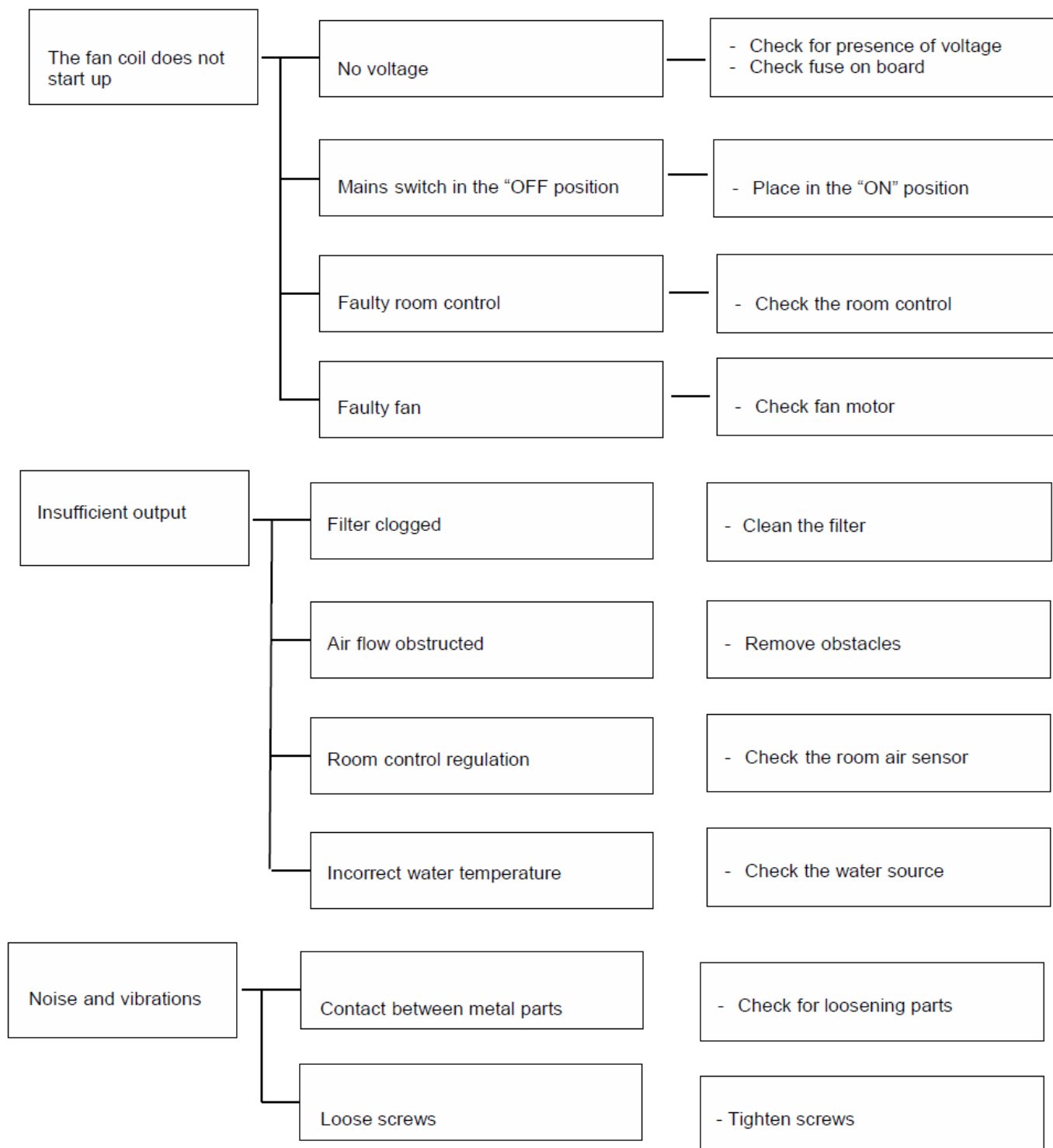



POLAR GLOBAL EUROPE HVAC SYSTEMS S.L.

C/ Rio Eresma 1, Polígono Industrial El Saladar,
Lorquí, 30564, Murcia, Spain

www.pghvac.com