

Description and application:

Grille intake and exhaust used in low and medium pressure industrial facilities or public areas where it is necessary to exchange a large amount of air. KSO/D is set installed primarily in the doors wings and garage doors, where is need to mask ventilation hole from one side and the other side the door. Installation is done by using visible screws in stamped holes in the grille frame. On request there is possibility of making the grille with a damper for regulating the air flow.

Grille has Hygienic Certificate HK/K/0522/02/2016

Material and workmanship

In standard grille is made of galvanized steel, whole grille is powder coated in white color RAL 9016. On request, it is possible to paint in any RAL color and execution of stainless steel or aluminum.

Size

Grilles are manufactured to order. Dimension grilles by the customer request (LxH).

Width of the frame for dimensions

L and H < 1000mm = 25mm

L and H > 1000mm = 50mm

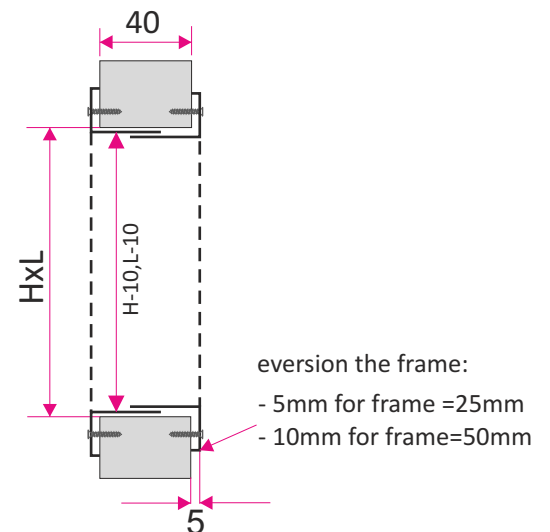
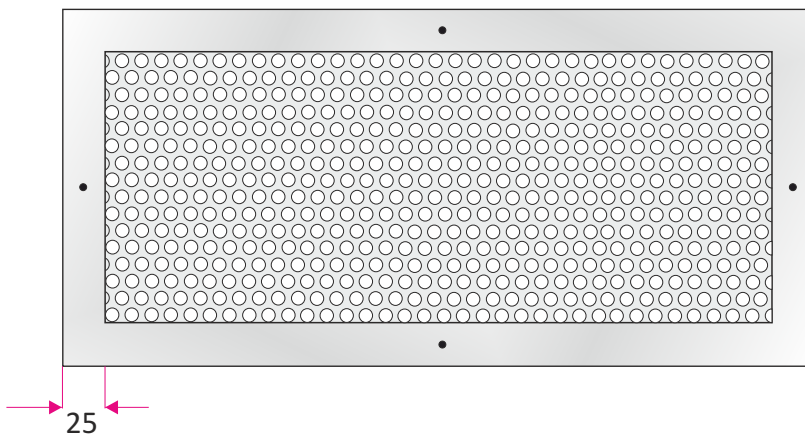

The effective area for the perforation Rv 8-10 (mesh φ8)

H \ L	125	225	325	425	525	625	825	1025	1225
mm	Aef (m ²) - effective area								
75	0,004	0,008	0,012	0,016	0,019	0,023	0,031	0,038	0,046
125	0,008	0,014	0,021	0,028	0,034	0,041	0,054	0,068	0,081
225		0,027	0,039	0,052	0,064	0,077	0,102	0,127	0,152
325			0,058	0,076	0,094	0,112	0,149	0,186	0,222
425				0,099	0,124	0,148	0,196	0,245	0,293
525					0,154	0,184	0,244	0,303	0,363
625						0,220	0,291	0,362	0,434

On request, grille can be made with perforations of different size and layout of the mesh, and the formula.

clearance relative:

Rv 4-6 - mesh φ4 - 40,31%

Rv 6-8 - mesh φ6 - 51,02%

Rv 8-10 - mesh φ8 - 58,05%

L and H grille mounting hole size

Quick selection

For $A_{ef}=0,022$ [m²] the smallest proposed dimensions [LxH] of grille:

- Rv 4-6 (clearance relative 40,31%) 825x75, 525x125, 325x225
- Rv 6-8 (clearance relative 51,02%) 825x75, 425x125, 225x225
- Rv 8-10 (clearance relative 58,05%) 625x75, 425x125, 225x225

Methods of mounting

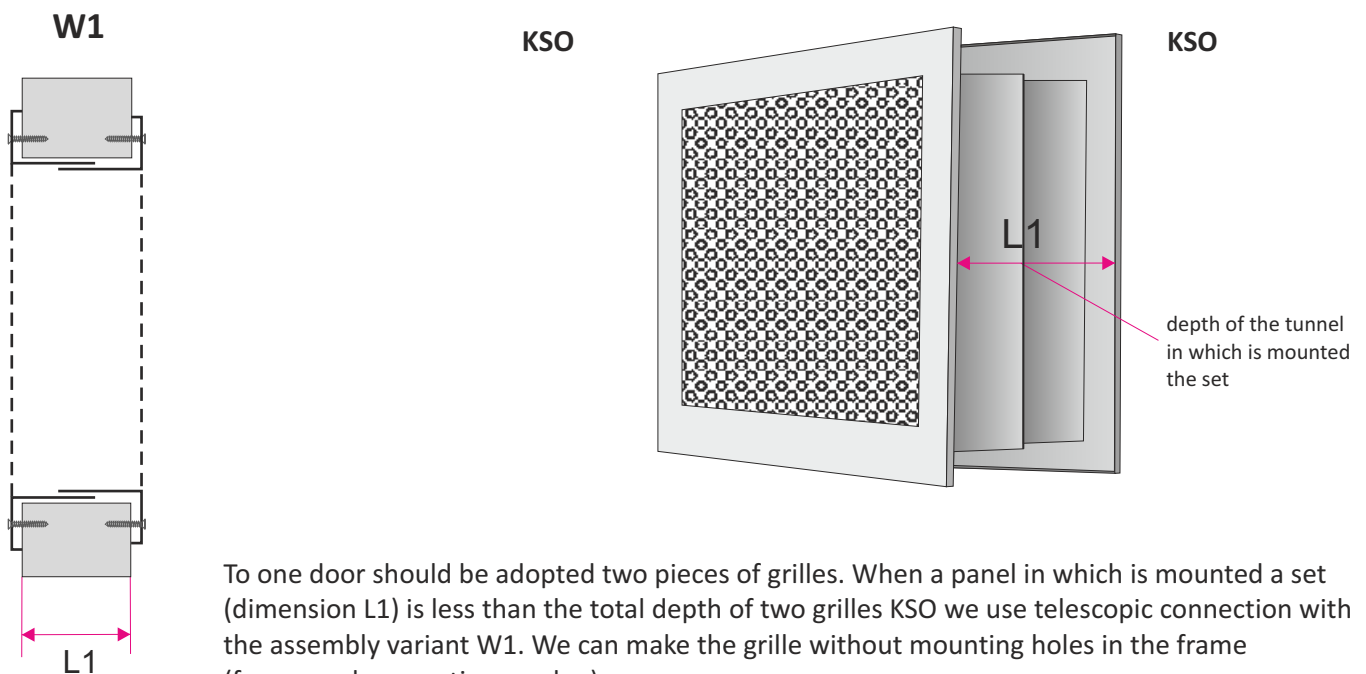

To one door should be adopted two pieces of grilles. When a panel in which is mounted a set (dimension L1) is less than the total depth of two grilles KSO we use telescopic connection with the assembly variant W1. We can make the grille without mounting holes in the frame (for example mounting on glue).

The method of placing an order

Please make orders according to the following formula:

KSO/D / 'LxH' / 'L1' / 'RAL' / 'M' / 'W'

'LxH'	- mounting hole size in doors (width x height) in mm
'L1'	- depth of the door panel
'RAL'	- grille color according to RAL palette (standard RAL9016*)
'M'	material:
	OC - powder coated steel*
	AL - aluminum powder coated
	KO - stainless steel / acid proof steel (type 1.4301 or 1.4404)

* - If you don't give the information will be used standard parameters.